

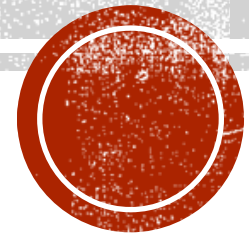

Indian Institute of Information Technology Allahabad

Data Structures and Algorithms

Height-balanced Tree (AVL Tree)



Dr. Shiv Ram Dubey

Associate Professor

Department of Information Technology

Indian Institute of Information Technology, Allahabad

Email: srdubey@iiita.ac.in

Web: <https://profile.iiita.ac.in/srdubey/>

DISCLAIMER

The content (text, image, and graphics) used in this slide are adopted from many sources for academic purposes. Broadly, the sources have been given due credit appropriately. However, there is a chance of missing out some original primary sources. The authors of this material do not claim any copyright of such material.

How long do these operations take in BST?

- **SEARCH** is the big one.
 - Everything else just calls **SEARCH** and then does some small $O(1)$ -time operation.

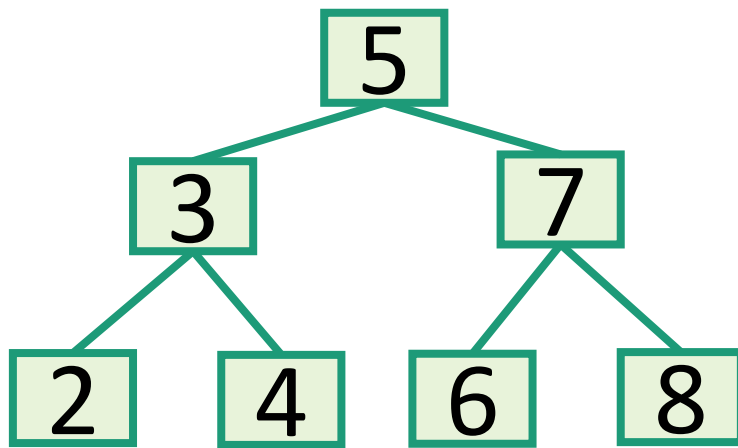

Time = $O(\text{height of tree})$

Trees have depth $O(\log(n))$.

Done!

Wait a second...



How long does search take?

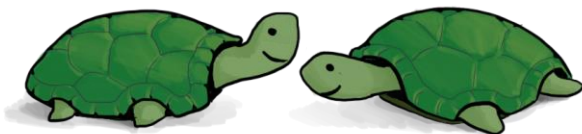

Search might take time $O(n)$ in BST

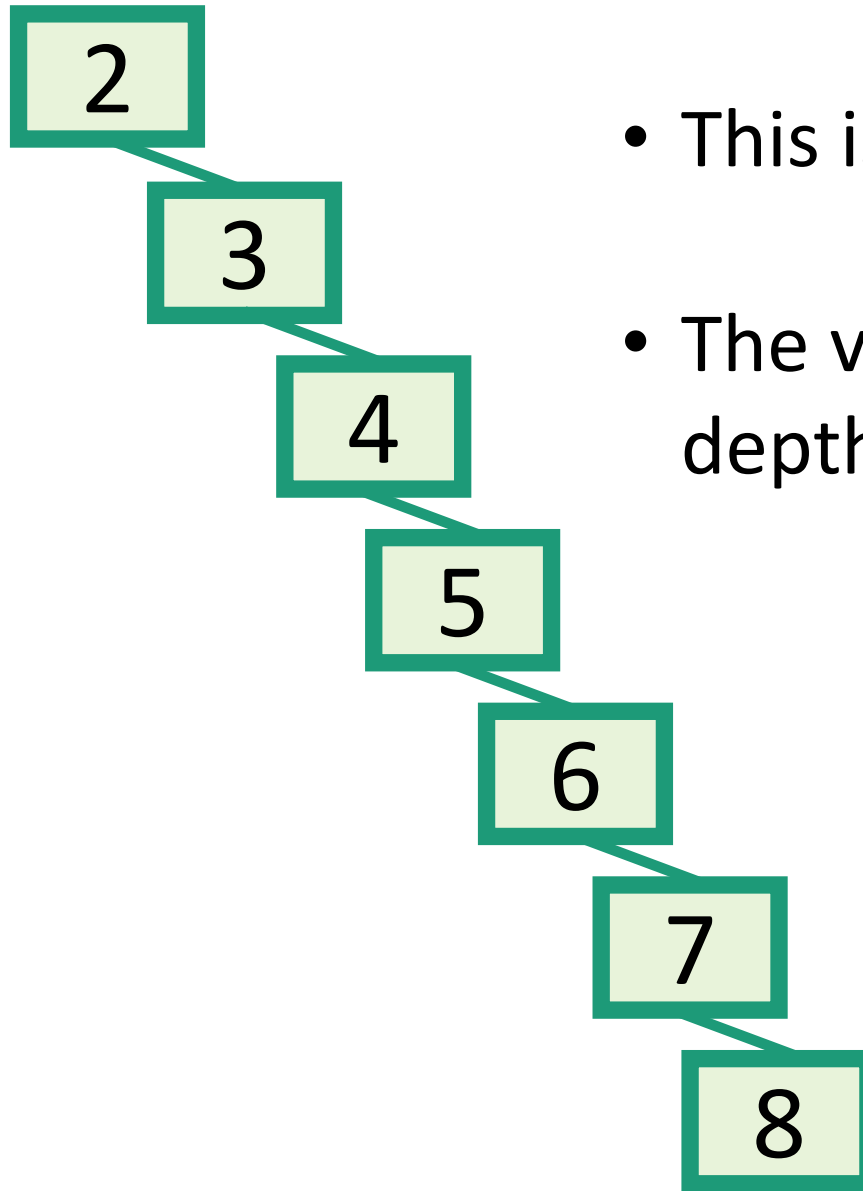

- This is a valid binary search tree.
- The version with n nodes has depth n , **not** $O(\log(n))$.

What to do?

- Goal: Fast **SEARCH/INSERT/DELETE**
- All these things take time $O(\text{height})$
- And the height might be big!!! 😞
- Idea 0:
 - Keep track of how deep the tree is getting.
 - If it gets too tall, re-do everything from scratch.
 - At least $\Omega(n)$ every so often....
- Turns out that's not a great idea. Instead we turn to...

How often is “every so often” in the worst case?
It's actually pretty often!



Self-Balancing Binary Search Trees

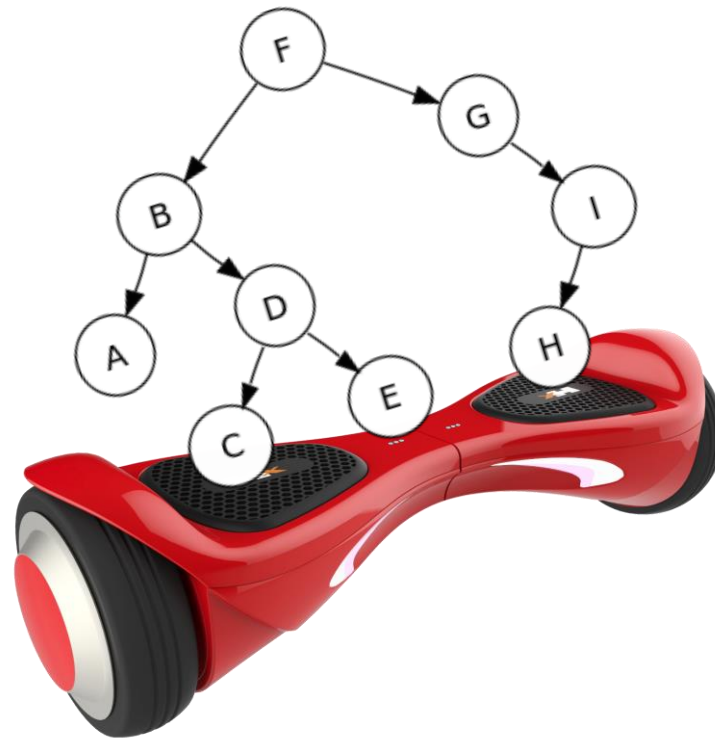

Idea 1: Rotations

No matter what lives underneath A,B,C, this takes time $O(1)$. (Why?)

- Maintain Binary Search Tree (BST) property, while moving stuff around.

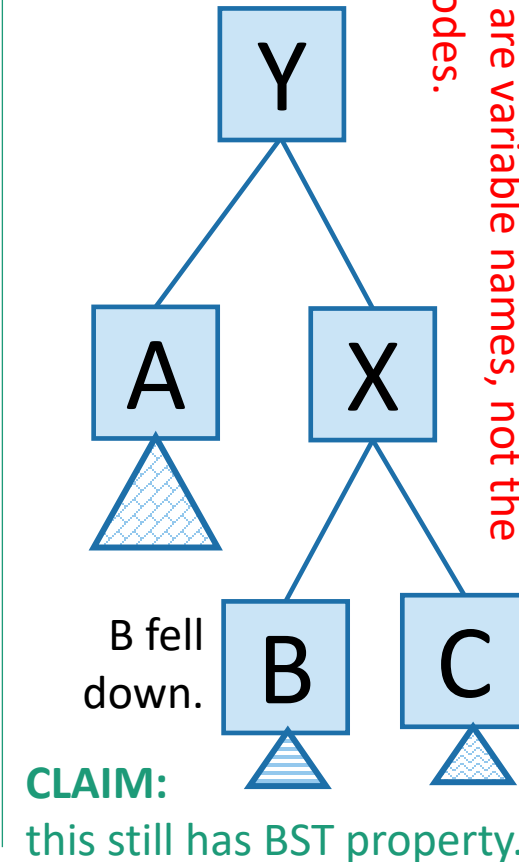
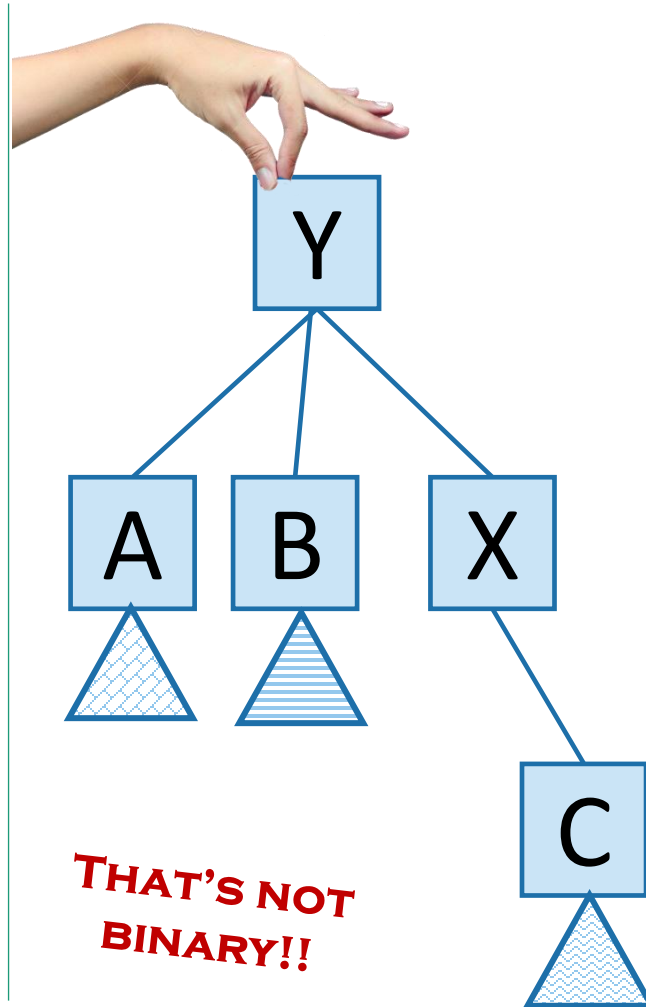
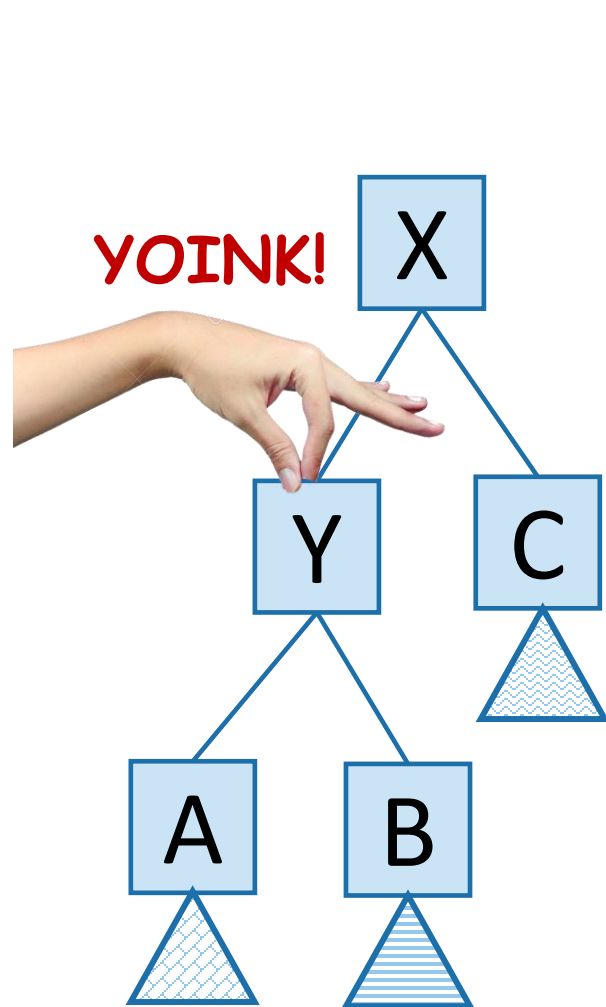

Note: A, B, C, X, Y are variable names, not the contents of the nodes.

This seems helpful

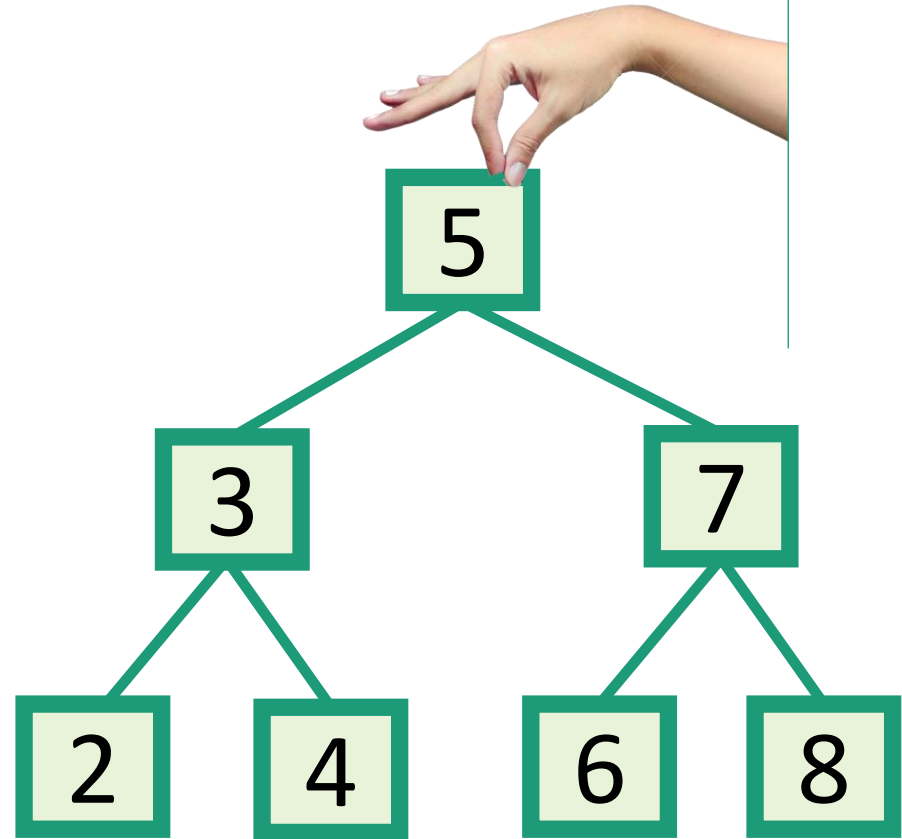
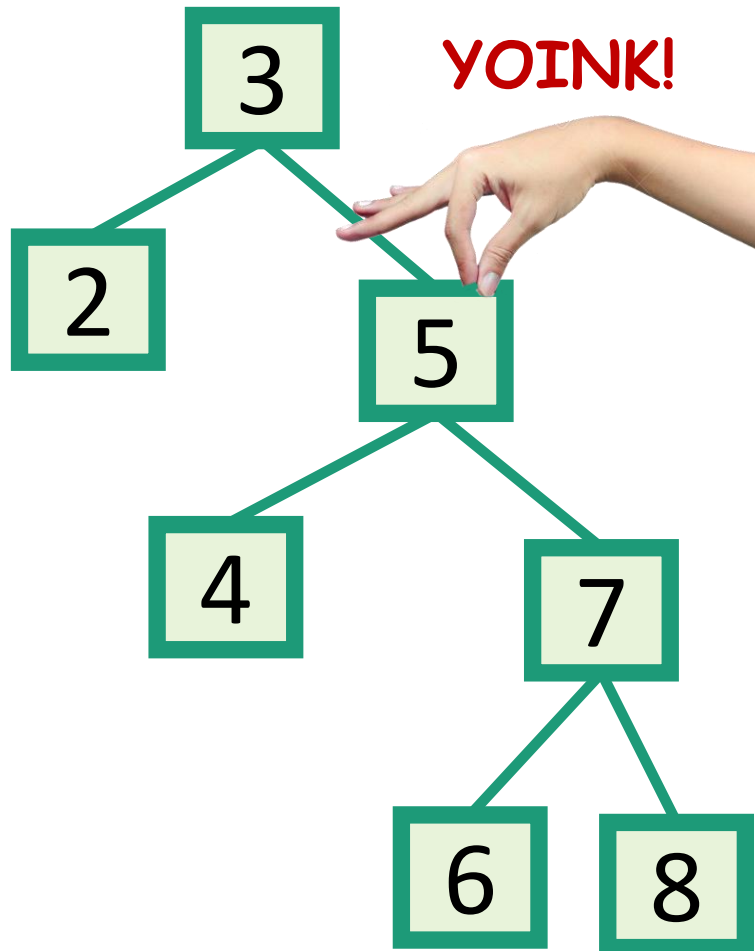

Strategy?

- Whenever something seems unbalanced, do rotations until it's okay again.



This is pretty vague.

What do we mean by
“seems unbalanced”?

What’s “okay”?

Idea 2: have some proxy for balance

- Maintaining **perfect balance** is too hard.
- Instead, come up with some **proxy for balance**:
 - If the tree satisfies **[SOME PROPERTY]**, then it's pretty balanced.
 - We can maintain **[SOME PROPERTY]** using rotations.



There are actually several ways to do this, but we'll see:

1. AVL Tree (In this course)
2. Multiway-Search Tree (2-4 Tree)
3. Red-Black Tree

Prototypical Examples

These two examples demonstrate how we can correct for imbalances: starting with this tree, add 1:

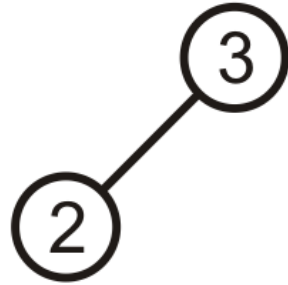

Prototypical Examples

This is more like a linked list; however, we can fix this...

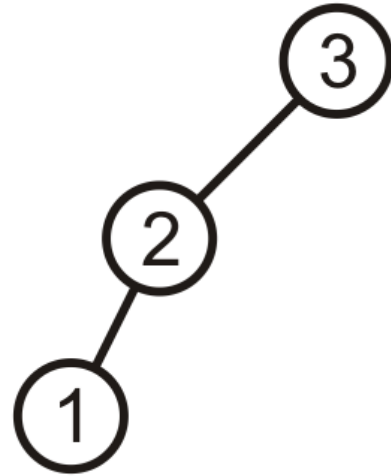

Prototypical Examples

Promote 2 to the root, demote 3 to be 2's right child, and 1 remains the left child of 2

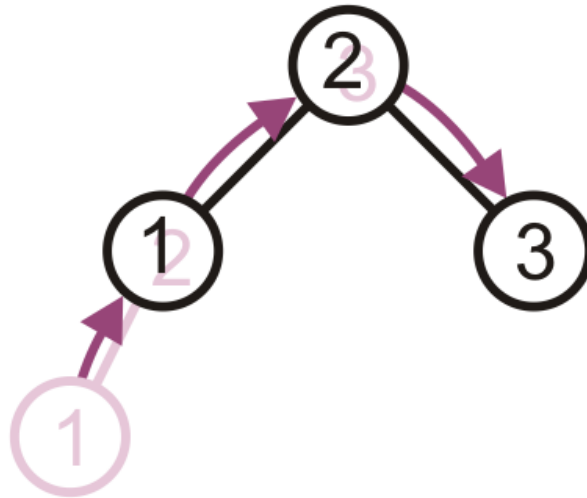

Prototypical Examples

The result is a perfect, though trivial tree

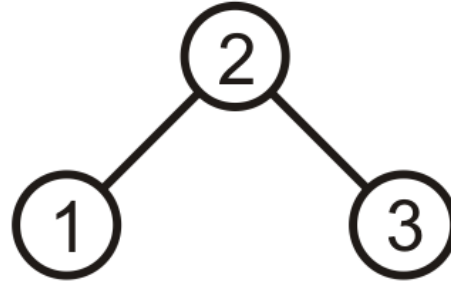

Prototypical Examples

Alternatively, given this tree, insert 2

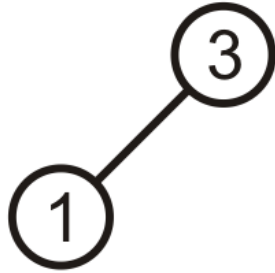

Prototypical Examples

Again, the product is a linked list; however, we can fix this, too

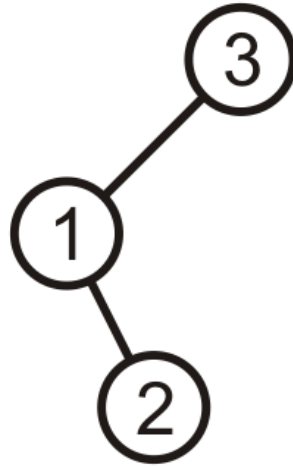

Prototypical Examples

The result is, again, a perfect tree

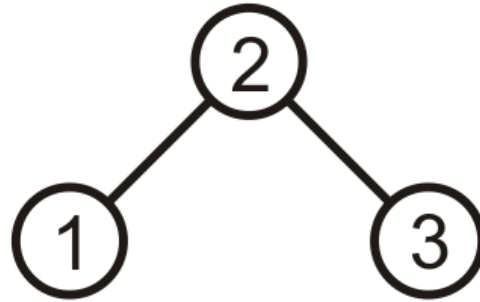

These examples may seem trivial, but they are the basis for the corrections in the next data structure we will see: AVL trees

AVL Trees

We will focus on the first strategy: AVL trees

- Named after Adelson-Velskii and Landis

Balance is defined by comparing the height of the two subtrees

Recall:

- An empty tree has height -1
- A tree with a single node has height 0

AVL Trees

A binary search tree is said to be AVL balanced if:

- The difference in the heights between the left and right sub-trees is at most 1, and
- Both sub-trees are themselves AVL trees

AVL Trees

AVL trees with 1, 2, 3, and 4 nodes:

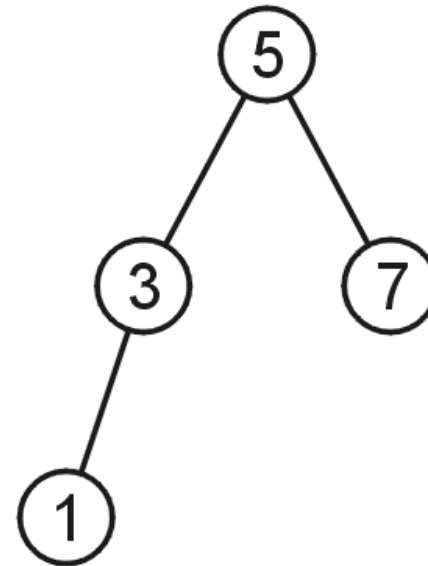
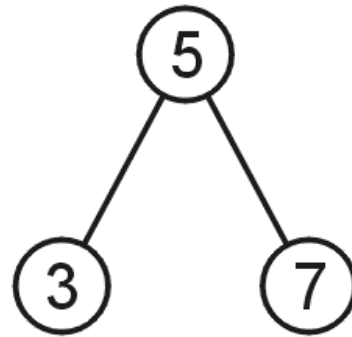
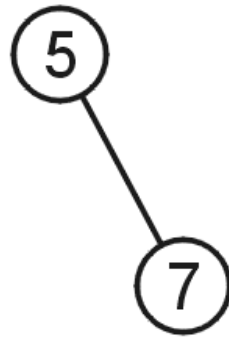

AVL Trees

Here is a larger AVL tree (42 nodes):

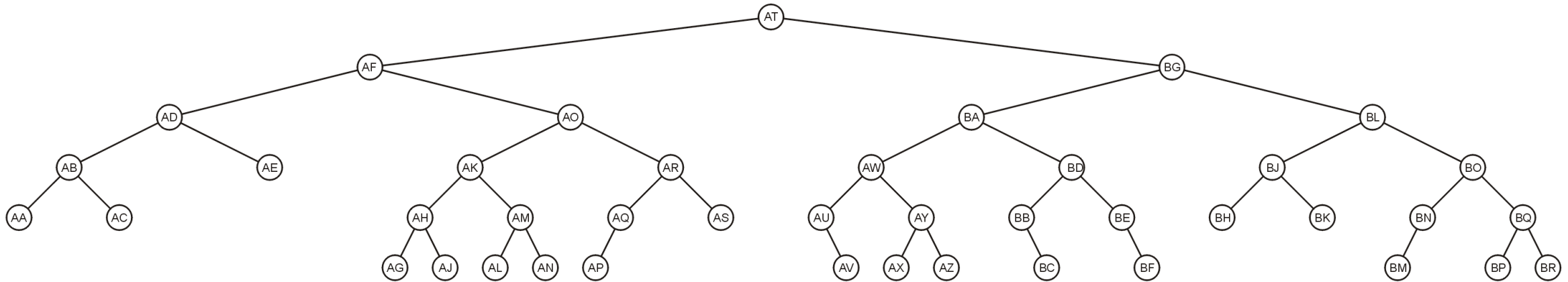

AVL Trees

The root node is AVL-balanced:

- Both sub-trees are of height 4:

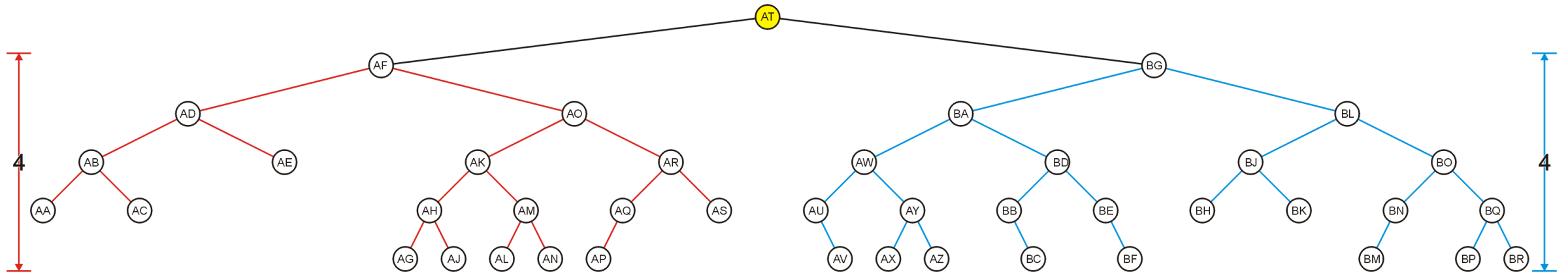

AVL Trees

All other nodes are AVL balanced

- The sub-trees differ in height by at most one

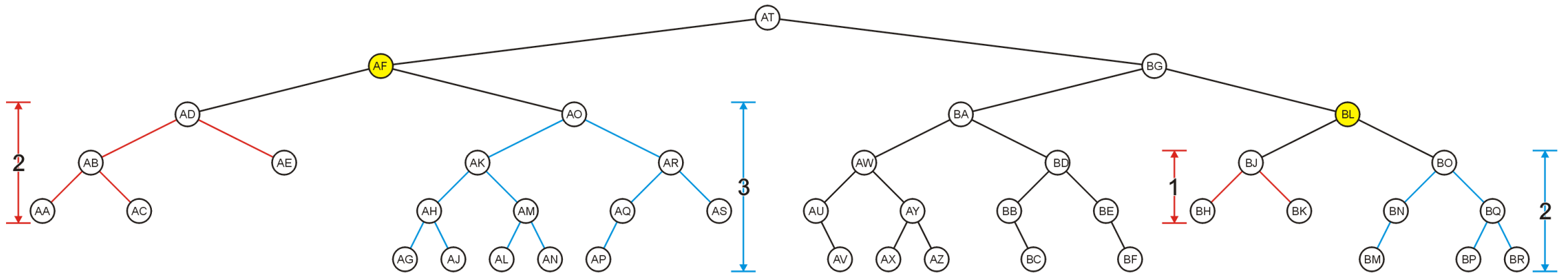

Height of an AVL Tree

- By the definition of complete trees, any complete binary search tree is an AVL tree
- Thus an upper bound on the number of nodes in an AVL tree of height h is a perfect binary tree with $2^{h+1} - 1$ nodes
 - What is an lower bound?

Height of an AVL Tree

Let $F(h)$ be the fewest number of nodes in a tree of height h

From a previous slide:

$$F(0) = 1$$

$$F(1) = 2$$

$$F(2) = 4$$

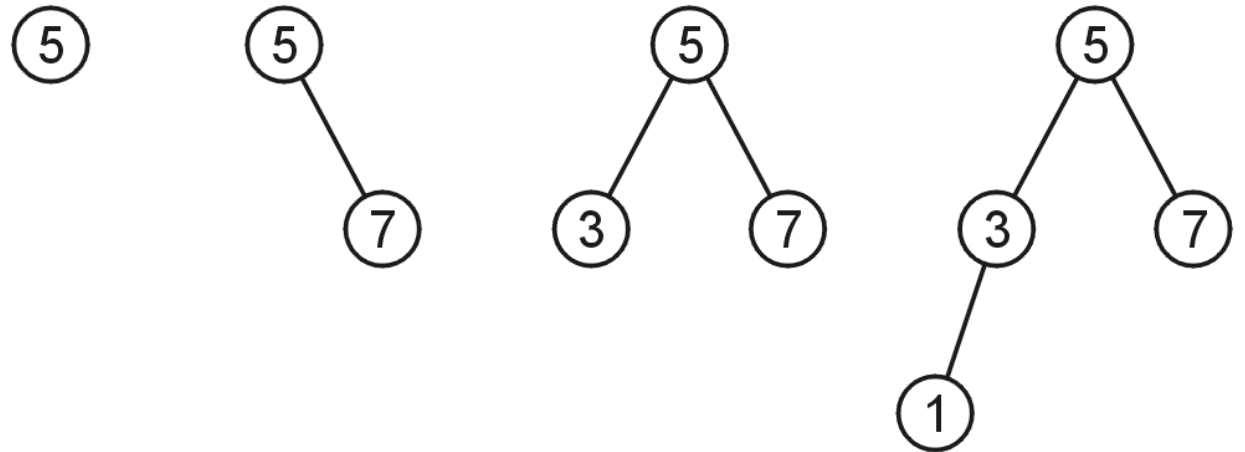

Can we find $F(h)$?

Height of an AVL Tree

The worst-case AVL tree of height h would have:

- A worst-case AVL tree of height $h - 1$ on one side,
- A worst-case AVL tree of height $h - 2$ on the other, and
- The **root** node

We get: $F(h) = F(h - 1) + 1 + F(h - 2)$

Height of an AVL Tree

This is a recurrence relation:

$$F(h) = \begin{cases} 1 & h = 0 \\ 2 & h = 1 \\ F(h-1) + F(h-2) + 1 & h > 1 \end{cases}$$

The solution?

Height of an AVL Tree

- **Fact:** The *height* of an AVL tree storing n keys is $O(\log n)$.
- **Proof:** Let us bound $n(h)$: the minimum number of internal nodes of an AVL tree of height h .
- We easily see that $n(1) = 1$ and $n(2) = 2$
- For $n > 2$, an AVL tree of height h contains the root node, one AVL subtree of height $h-1$ and another of height $h-2$.
- That is, $n(h) = 1 + n(h-1) + n(h-2)$
- Knowing $n(h-1) > n(h-2)$, we get $n(h) > 2n(h-2)$. So
 - $n(h) > 2n(h-2)$, $n(h) > 4n(h-4)$, $n(h) > 8n(h-6)$, ... (by induction),
 - $n(h) > 2^i n(h-2i)$
- Solving the base case we get: $n(h) > 2^{h/2-1}$
- Taking logarithms: $h < 2\log n(h) + 2$
- Thus the height of an AVL tree is $O(\log n)$

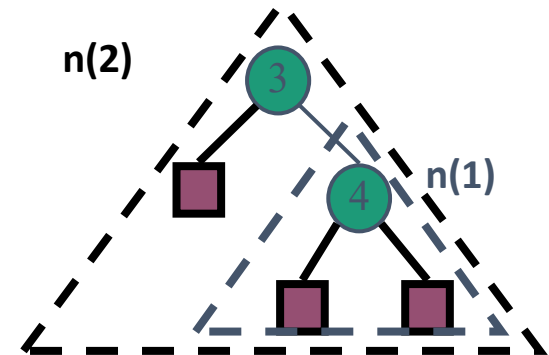

Maintaining Balance

To maintain AVL balance, observe that:

- Inserting a node can increase the height of a tree by at most 1
- Removing a node can decrease the height of a tree by at most 1

Maintaining Balance

Consider this AVL tree

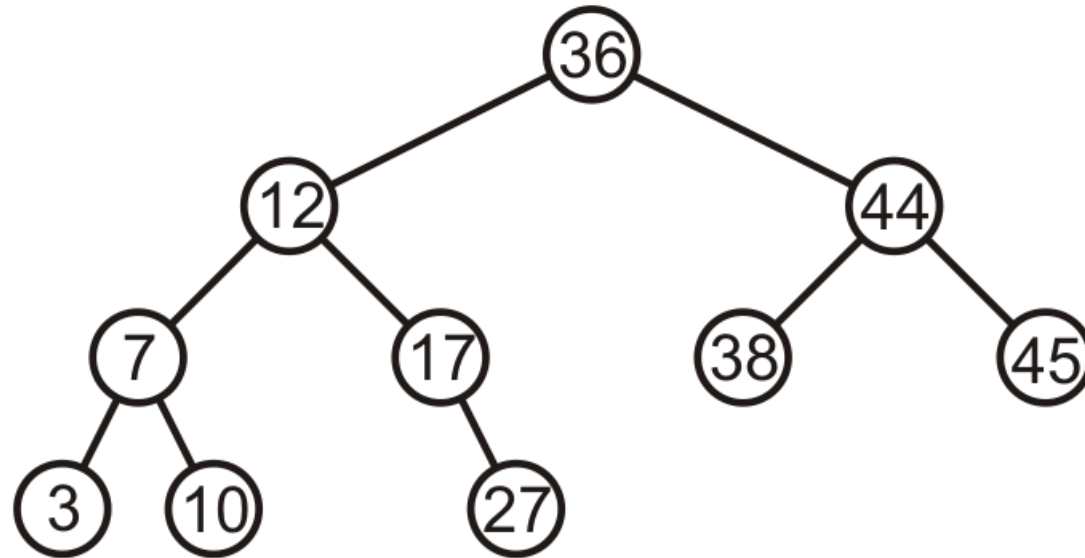

Maintaining Balance

Consider inserting 15 into this tree

- In this case, the heights of none of the trees change

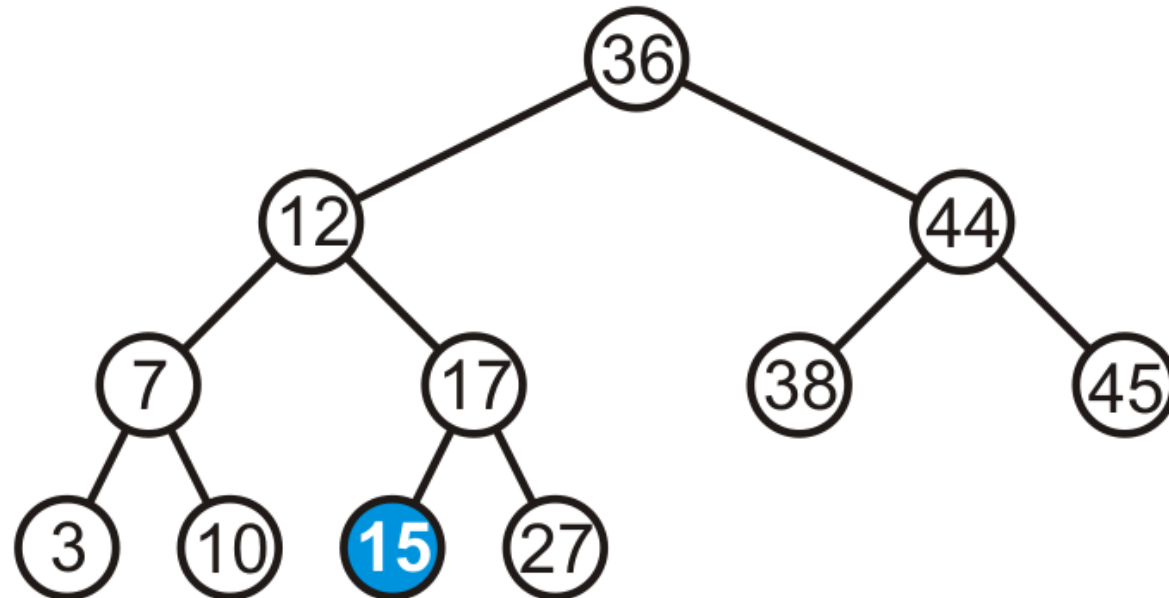

Maintaining Balance

The tree remains balanced

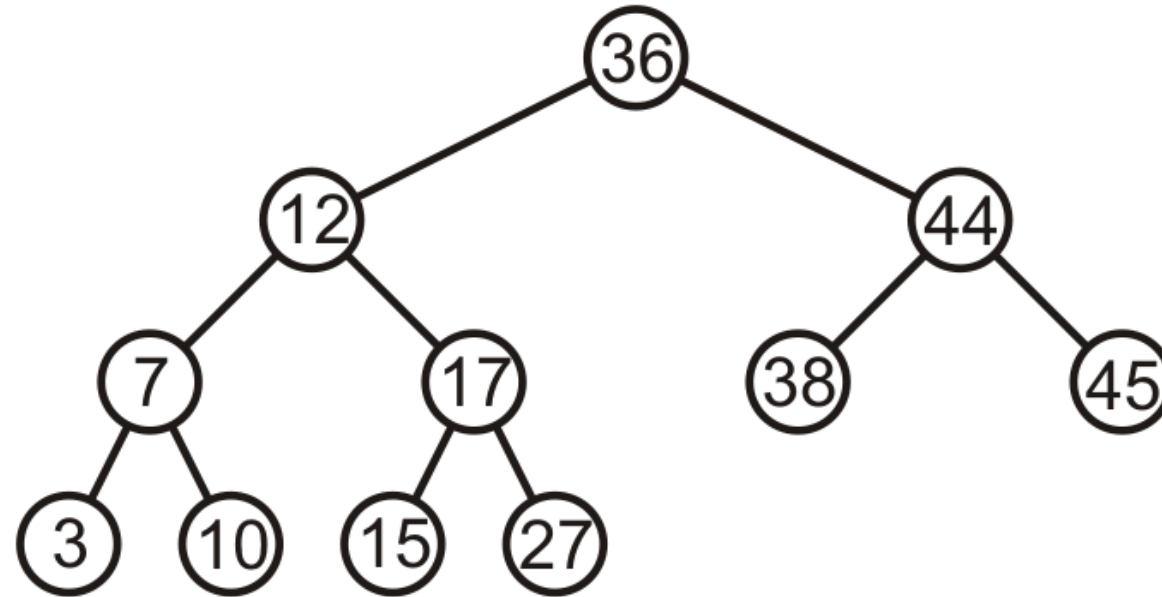

Maintaining Balance

Consider inserting 42 into this tree

- In this case, the heights of none of the trees change

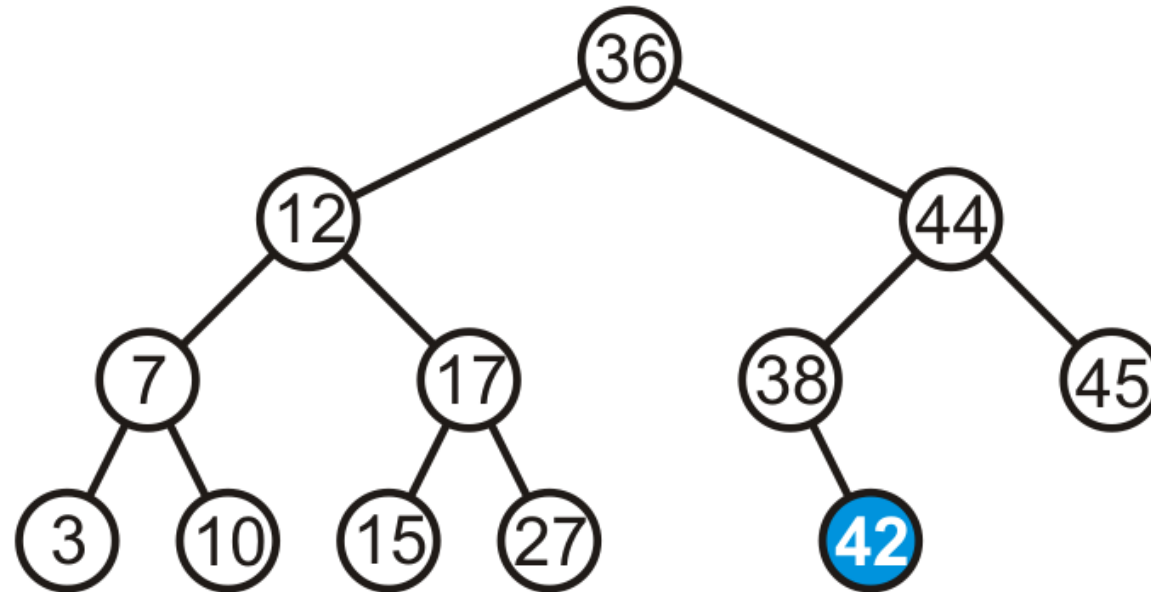

Maintaining Balance

If a tree is AVL balanced, for an insertion to cause an imbalance:

- The heights of the sub-trees must differ by 1
- The insertion must increase the height of the deeper sub-tree by 1

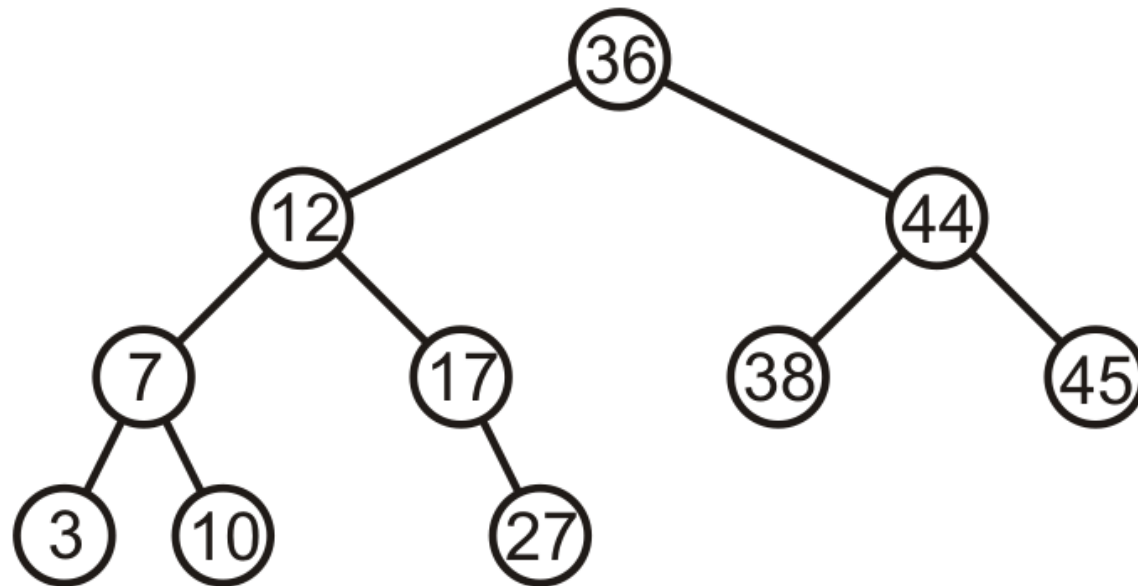

Maintaining Balance

Suppose we insert 23 into our initial tree

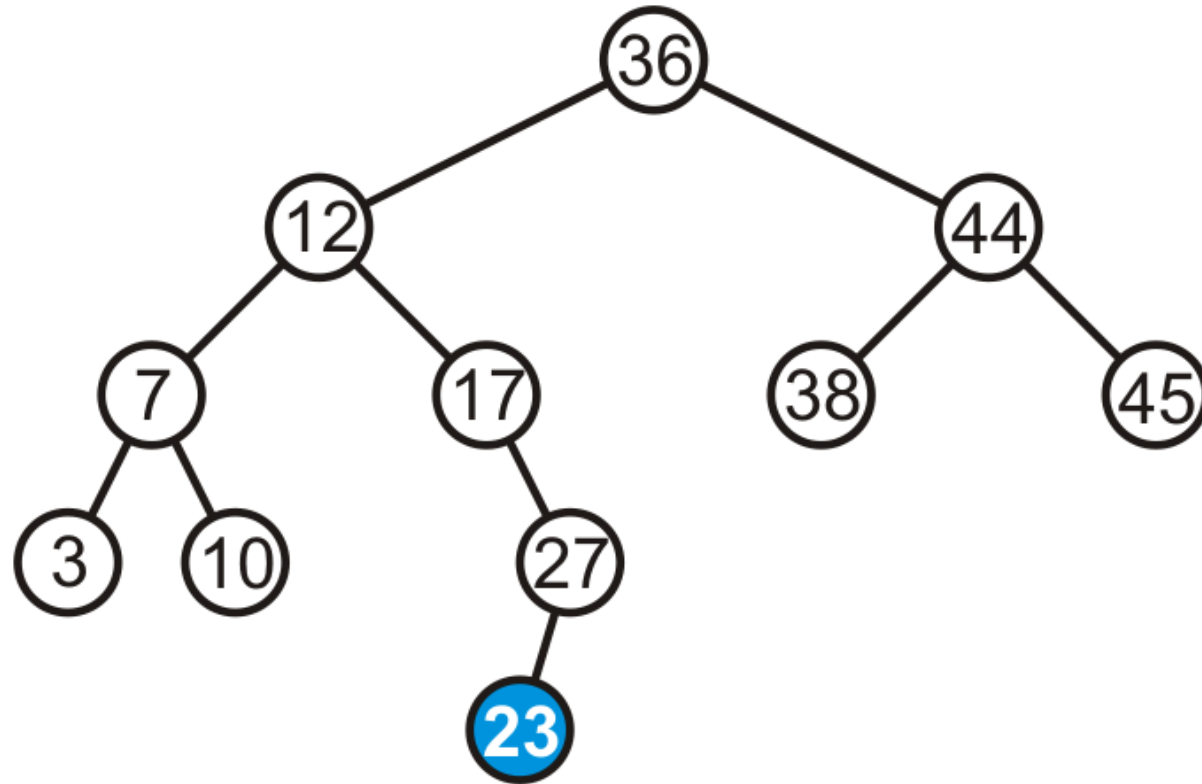

Maintaining Balance

The heights of each of the sub-trees from here to the root are increased by one

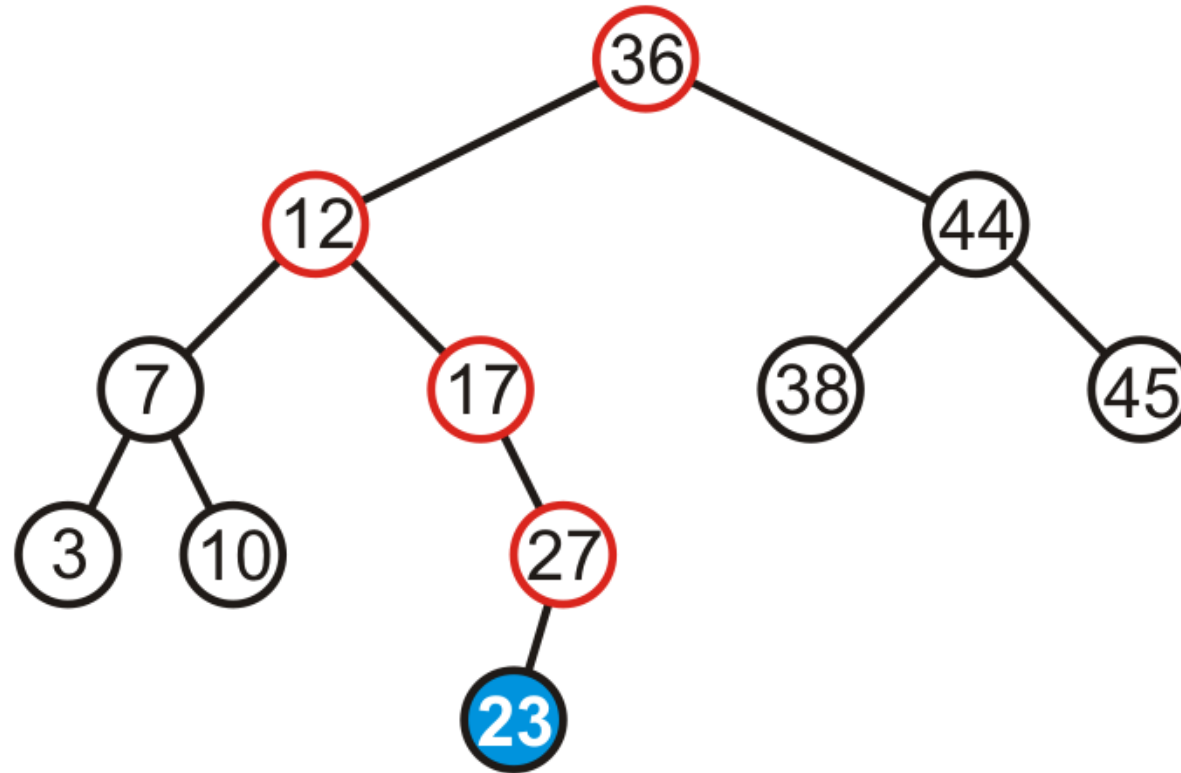

Maintaining Balance

However, only two of the nodes are unbalanced: 17 and 36

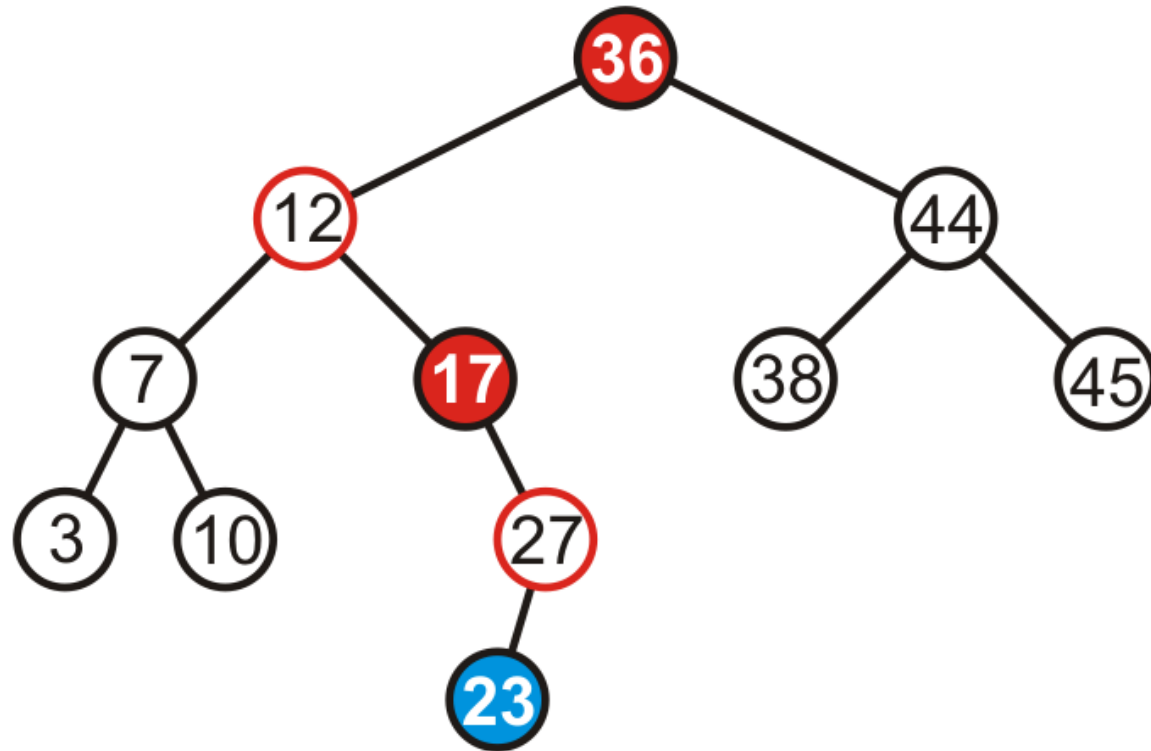

Maintaining Balance

However, only two of the nodes are unbalanced: 17 and 36

- We only have to fix the imbalance at the lowest node

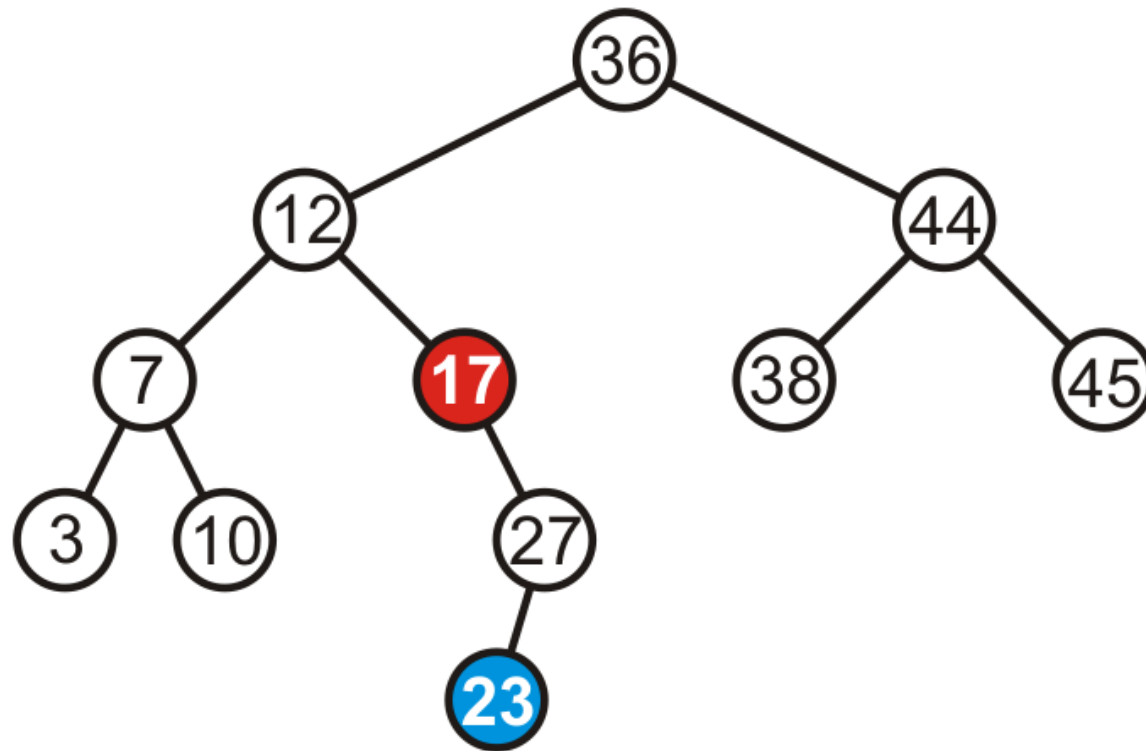

Maintaining Balance

We can promote 23 to where 17 is, and make 17 the left child of 23

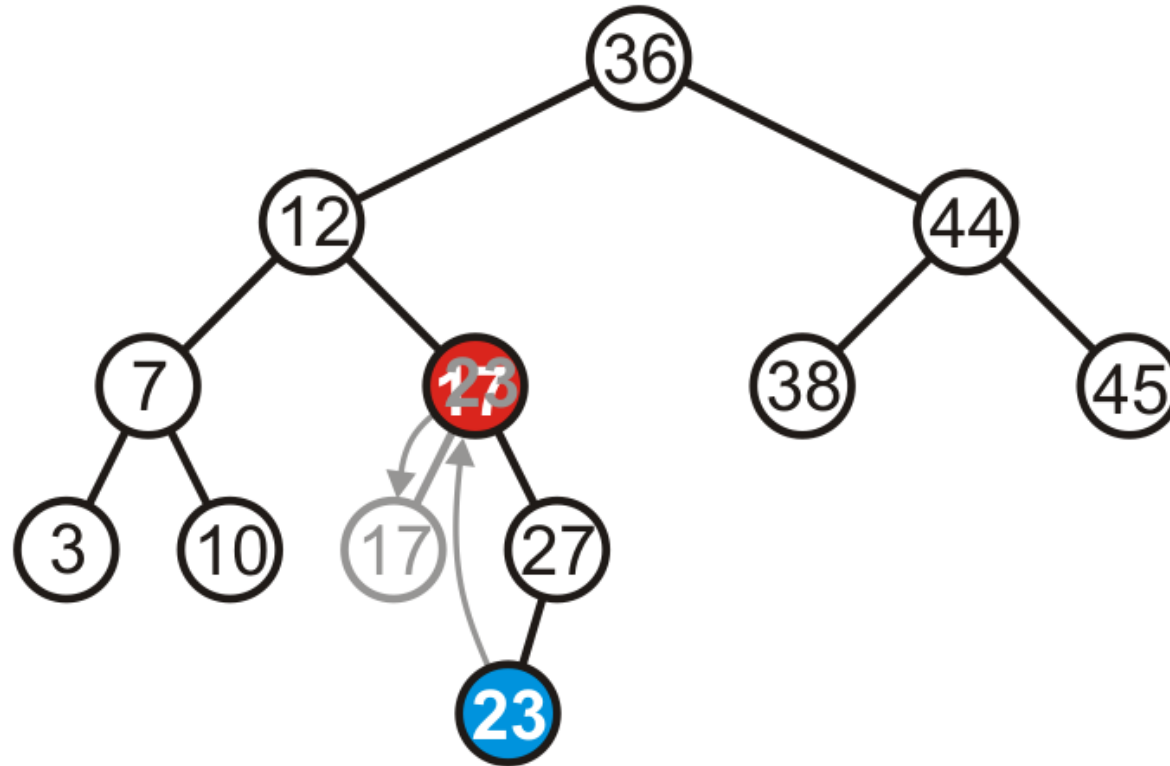

Maintaining Balance

Thus, that node is no longer unbalanced

- Incidentally, neither is the root now balanced again, too

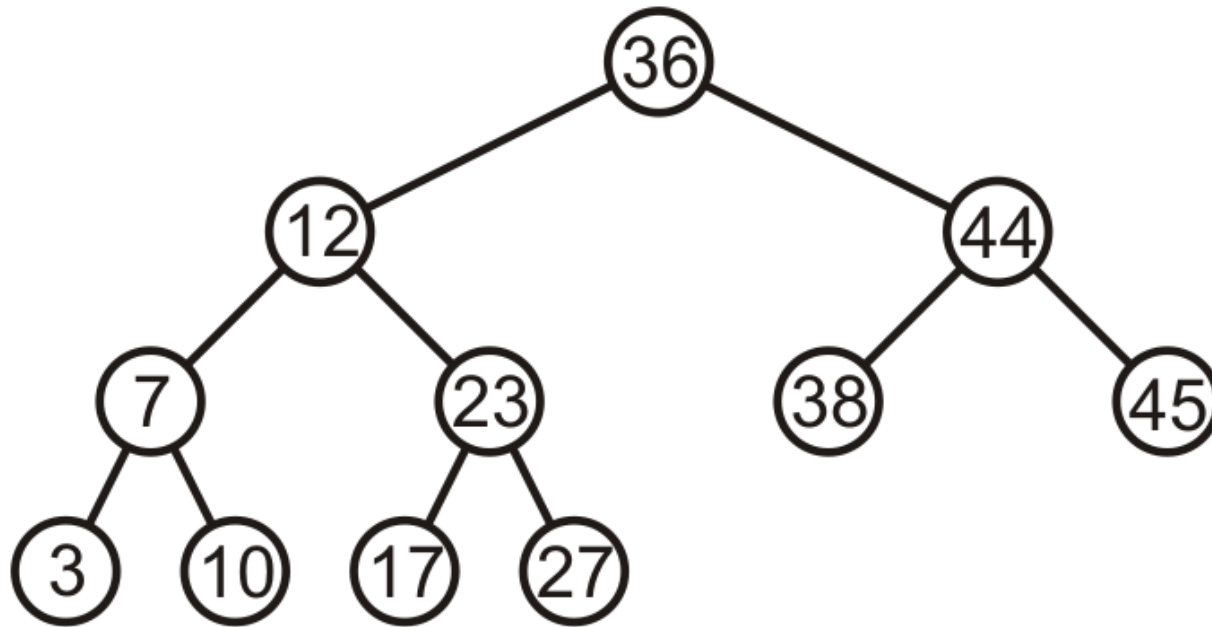

Maintaining Balance

Consider adding 6:

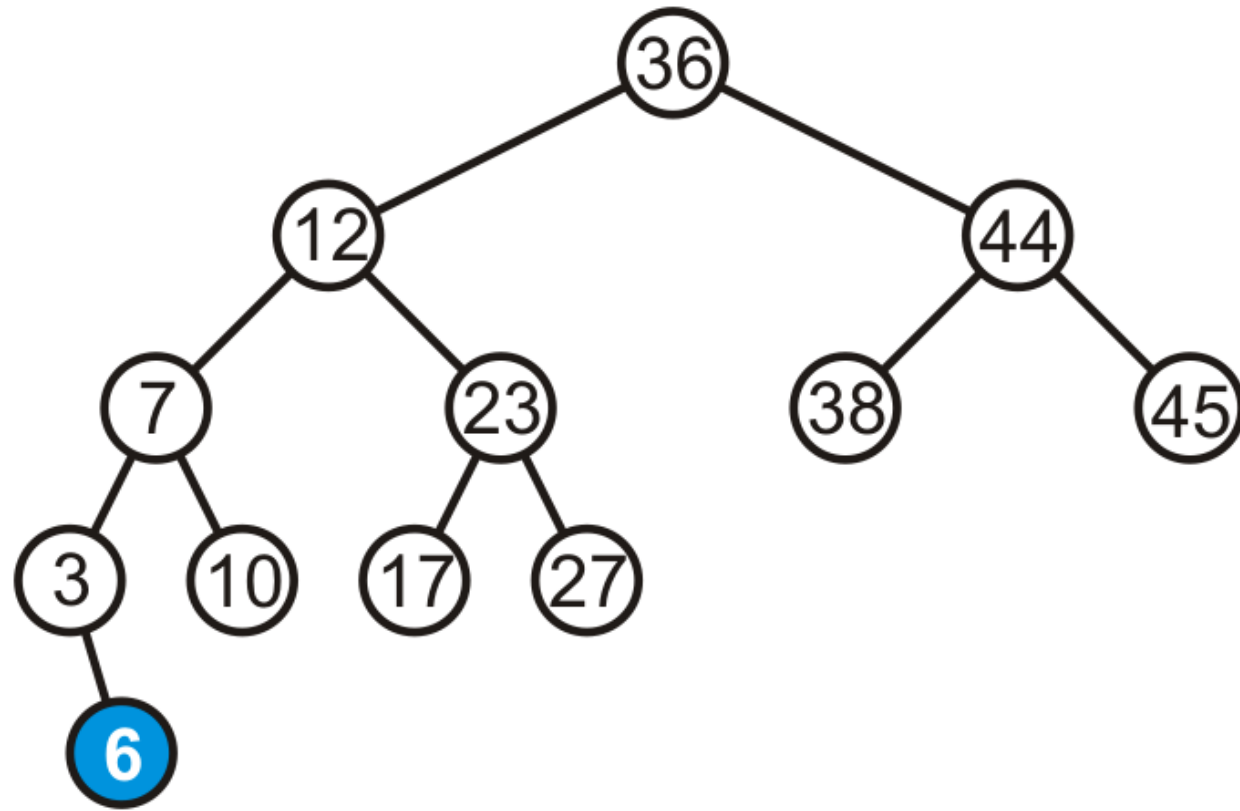

Maintaining Balance

The height of each of the trees in the path back to the root are increased by one

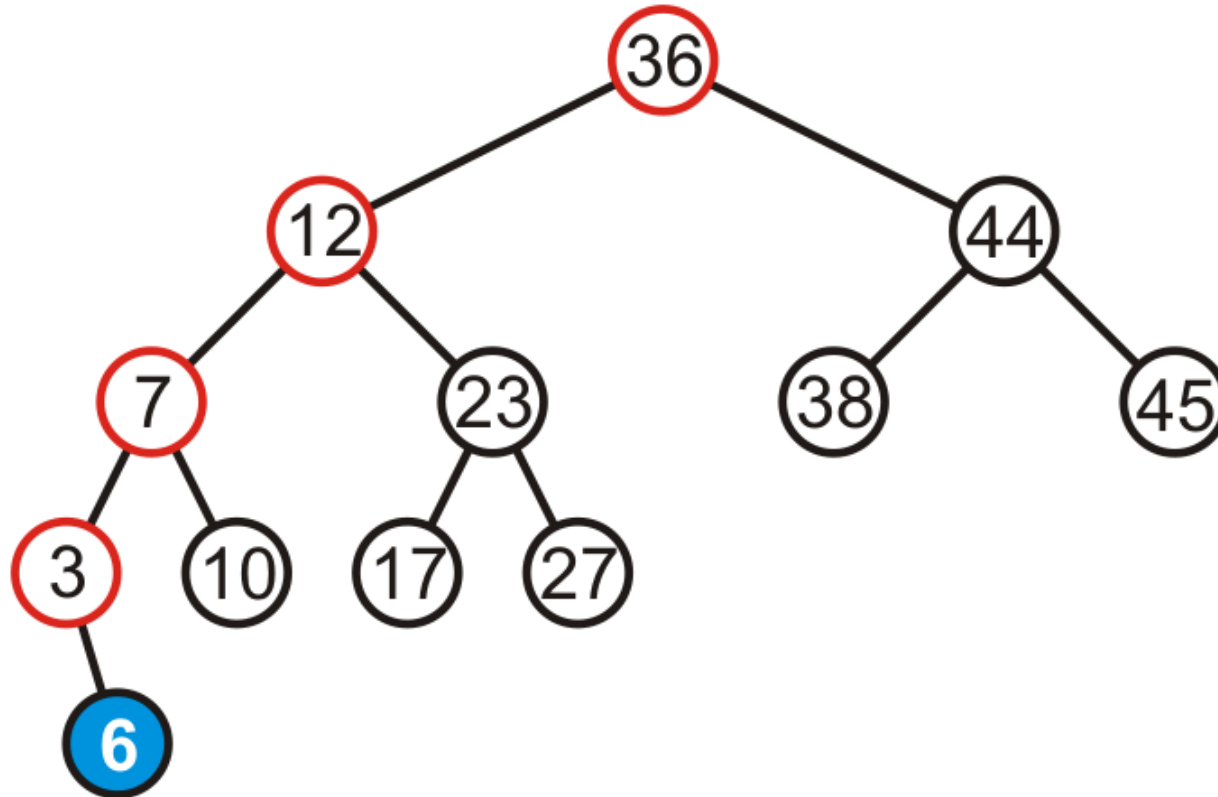

Maintaining Balance

The height of each of the trees in the path back to the root are increased by one

- However, only the root node is now unbalanced

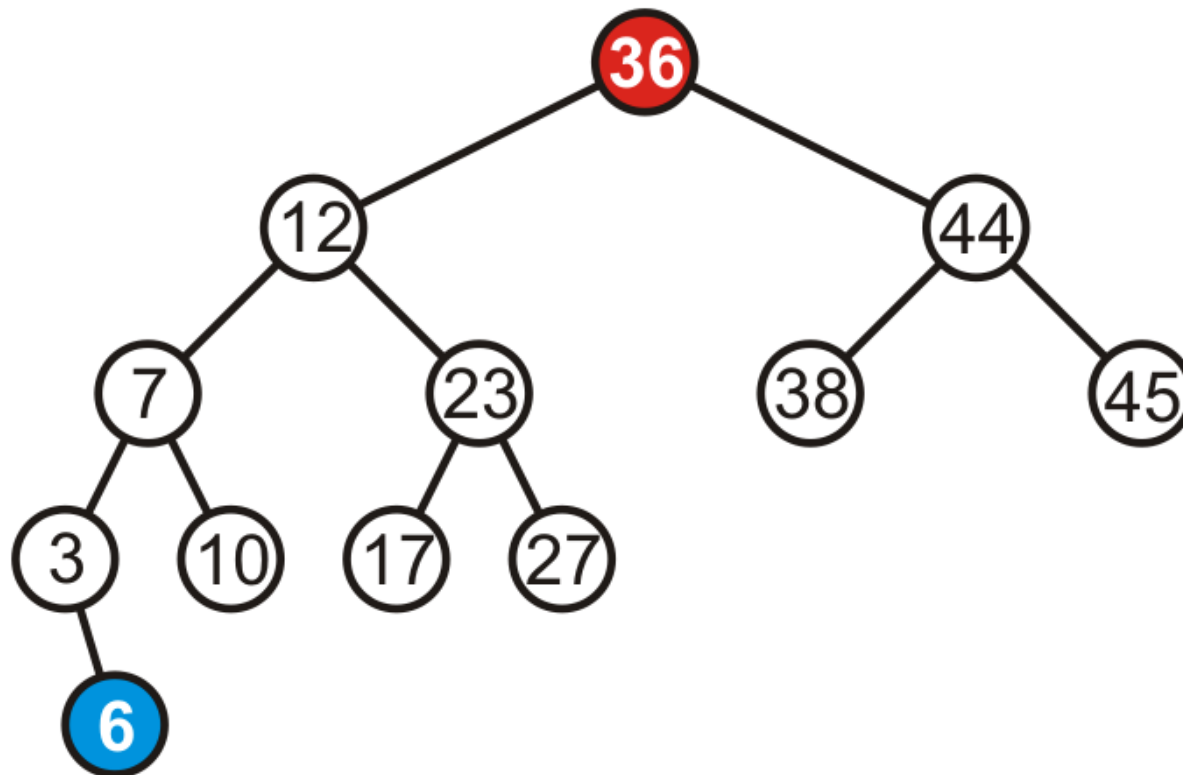

Maintaining Balance

We may fix this by rotating the root to the right

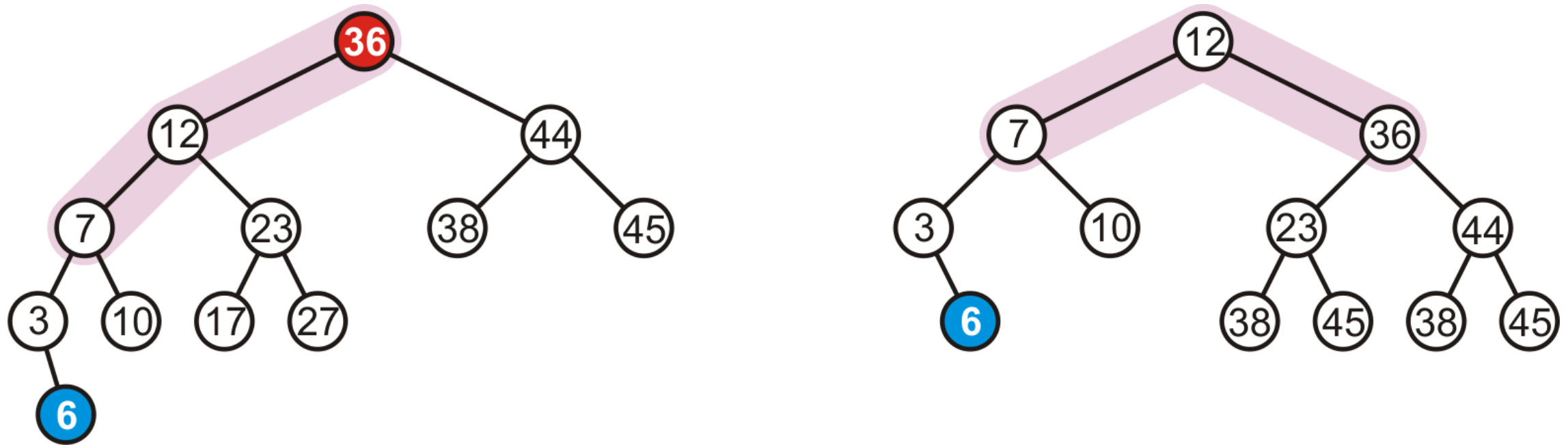

Note: the right subtree of 12 became the left subtree of 36

Case 1 setup

Consider the following setup

- Each blue triangle represents a tree of height h

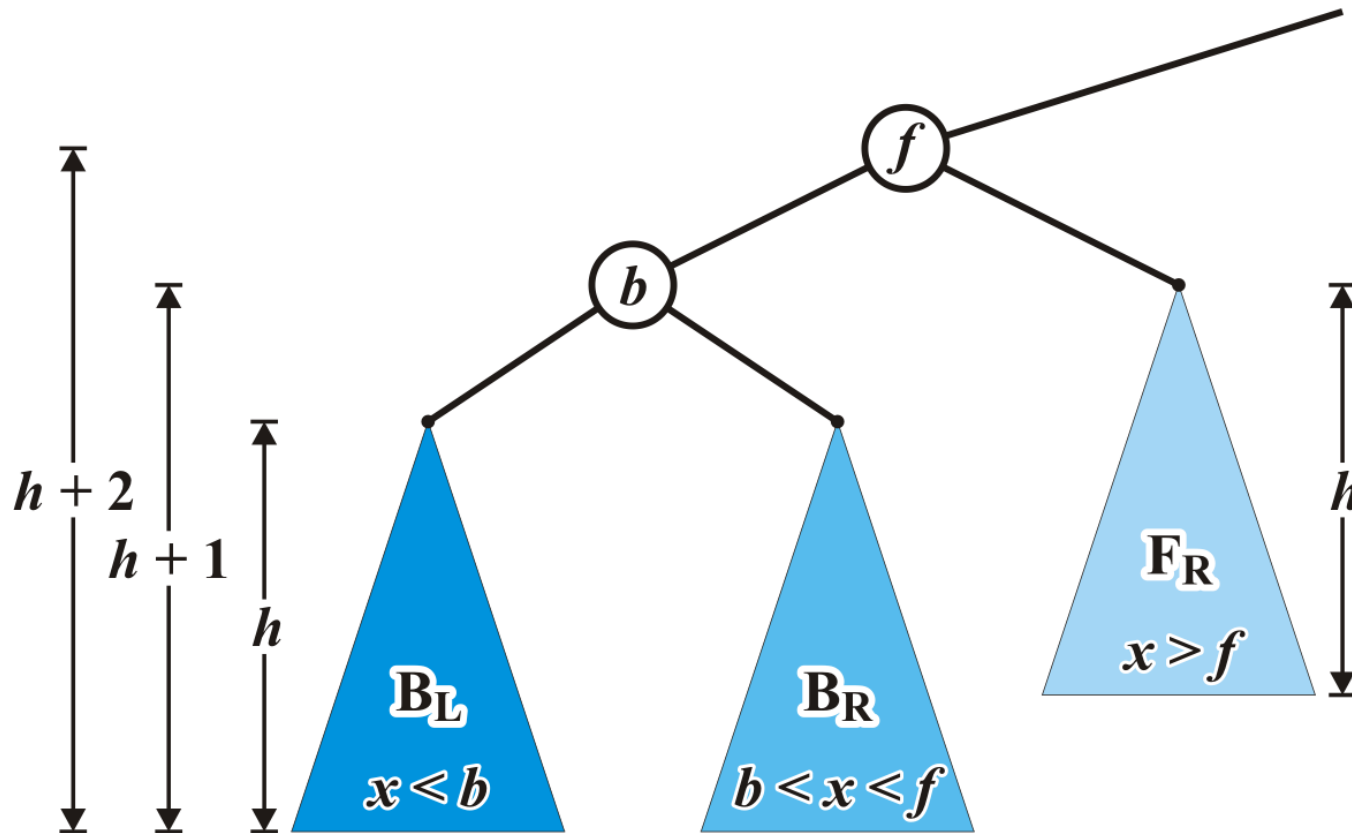

Maintaining Balance: Case 1

Insert a into this tree: it falls into the **left subtree B_L** of b

- Assume B_L remains balanced
- Thus, the tree rooted at b is also balanced

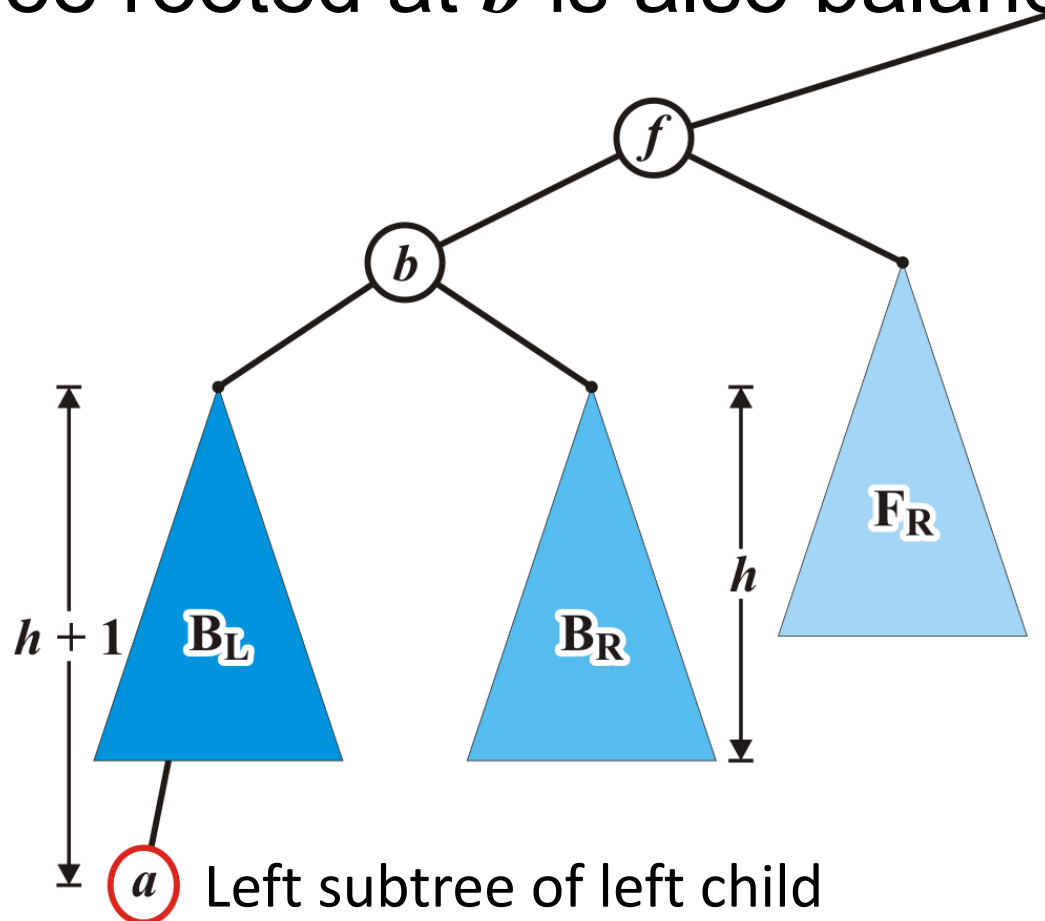

Maintaining Balance: Case 1

The tree rooted at node f is now unbalanced

- We will correct the imbalance at this node

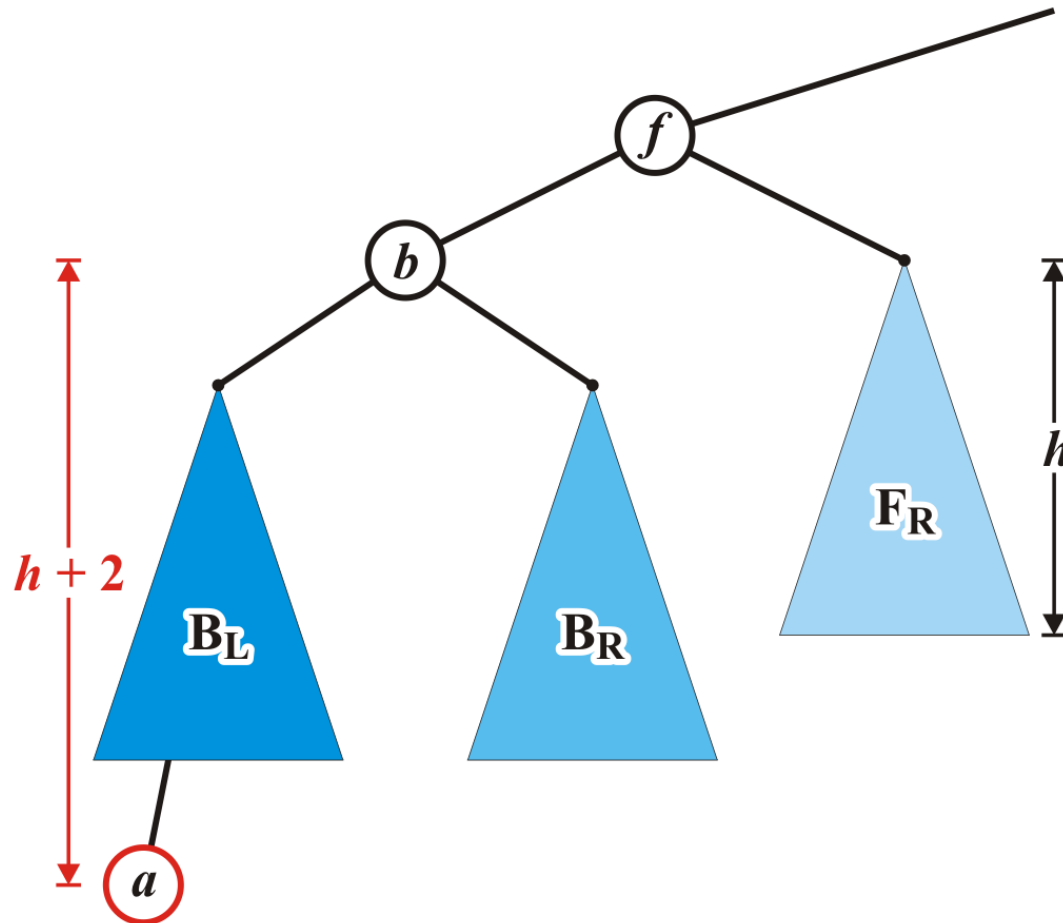

Maintaining Balance: Case 1

We will modify these three pointers:

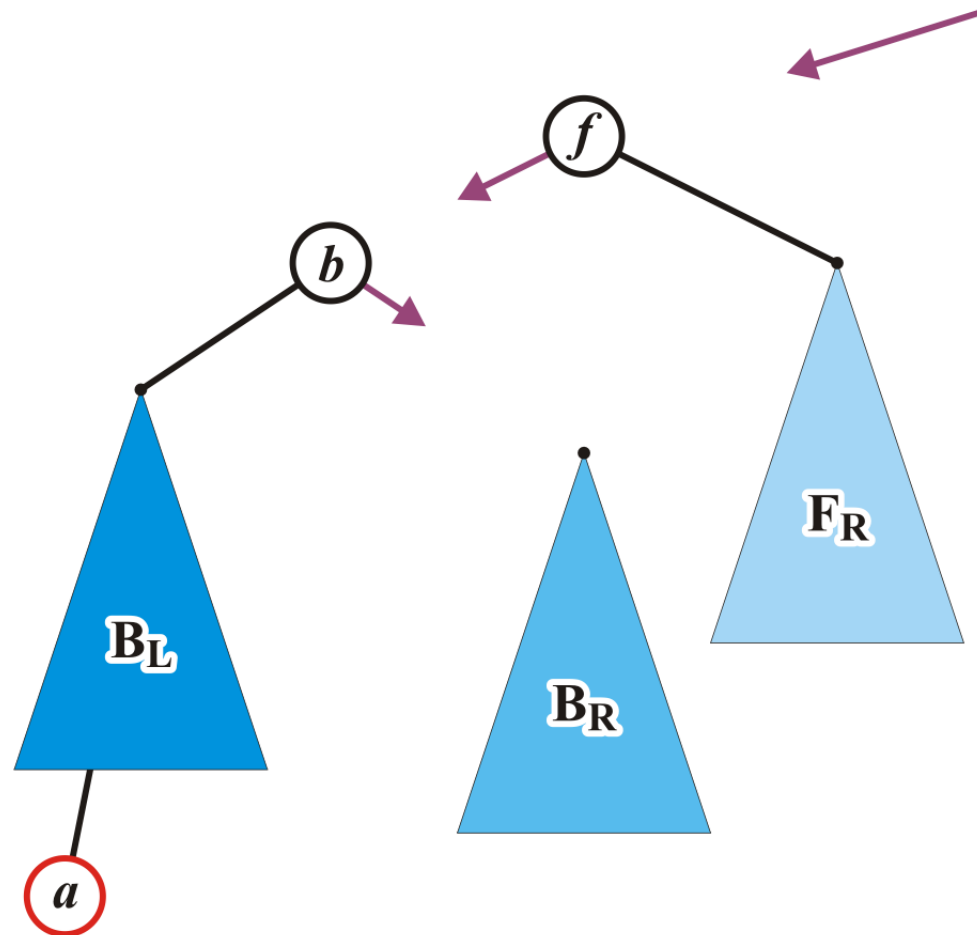

Maintaining Balance: Case 1

Specifically, we will rotate these two nodes around the root:

- Recall the first prototypical example
- Promote node b to the root and demote node f to be the right child of b

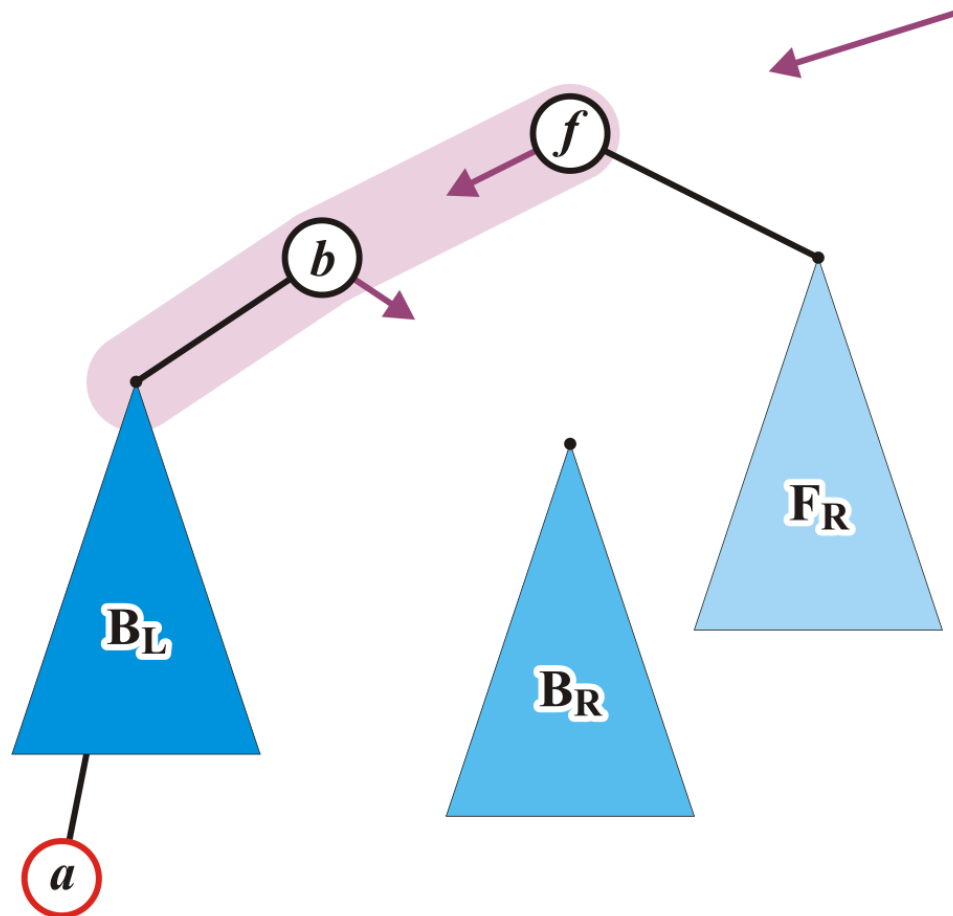

Maintaining Balance: Case 1

Make f the right child of b

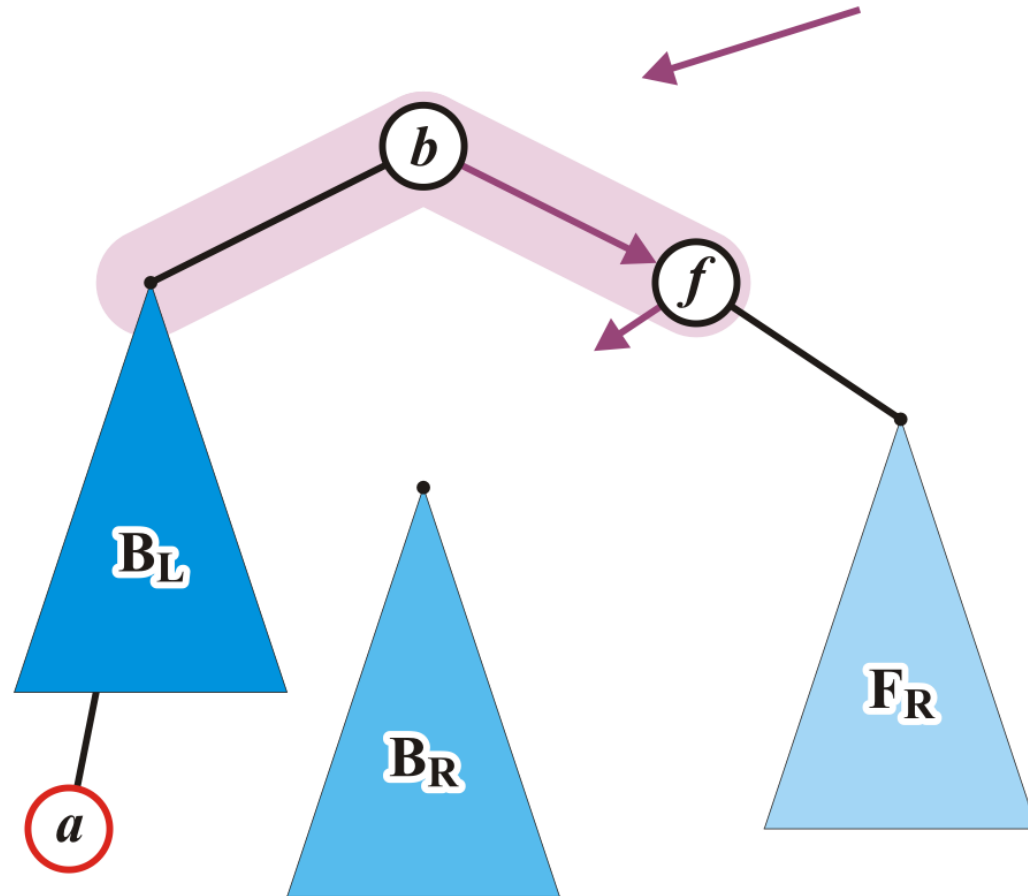

Maintaining Balance: Case 1

Assign former parent of node f to point to node b

Make \mathbf{B}_R left child of node f

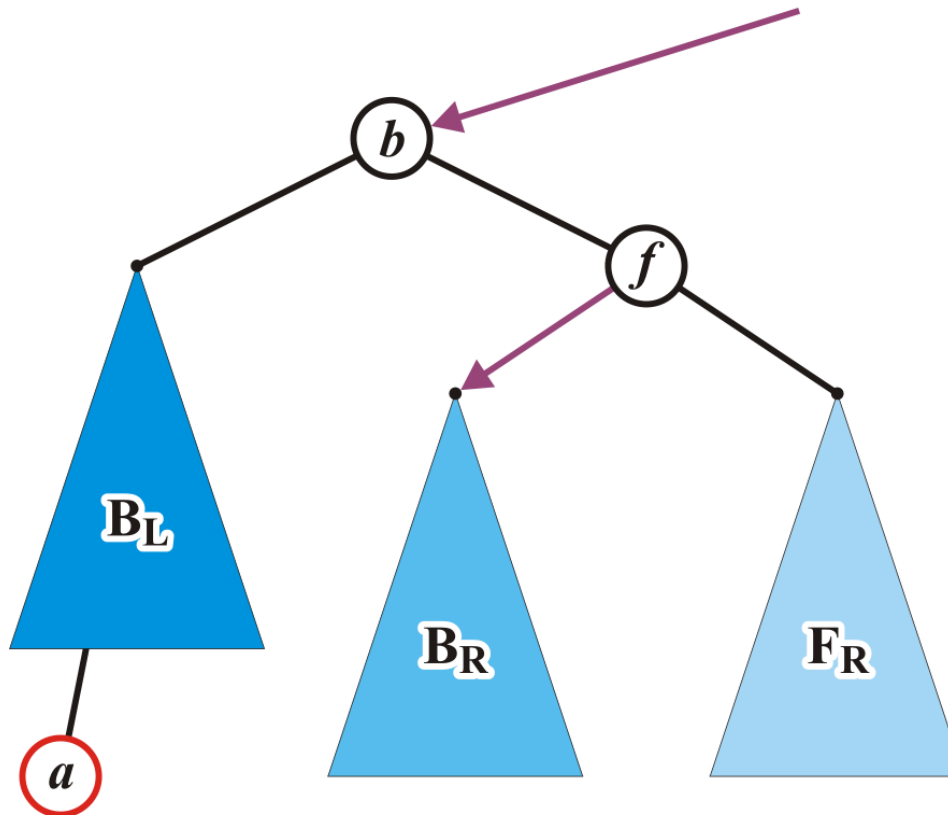

Maintaining Balance: Case 1

The nodes b and f are now balanced and all remaining nodes of the subtrees are in their correct positions

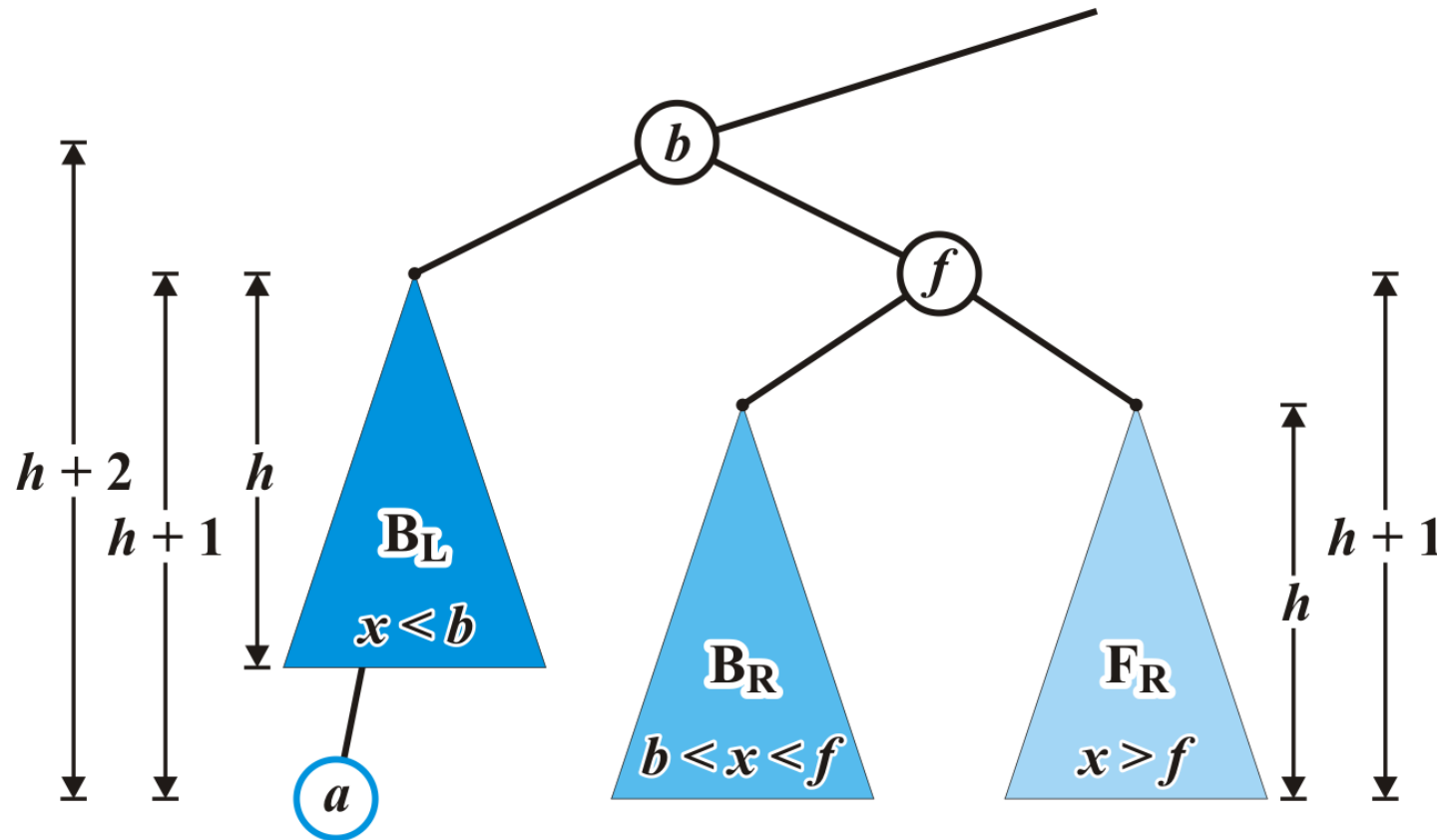

Maintaining Balance: Case 1

Additionally, height of the tree rooted at b equals the original height of the tree rooted at f

- Thus, this insertion will no longer affect the balance of any ancestors all the way back to the root

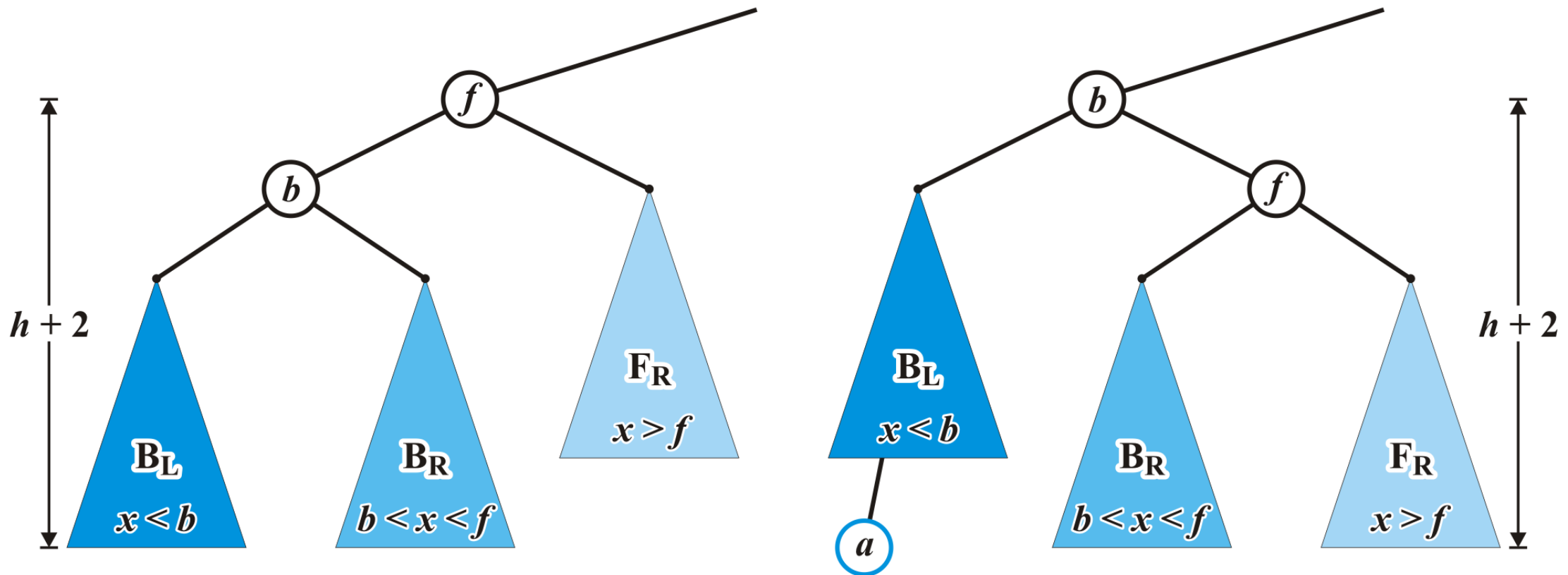

More Examples

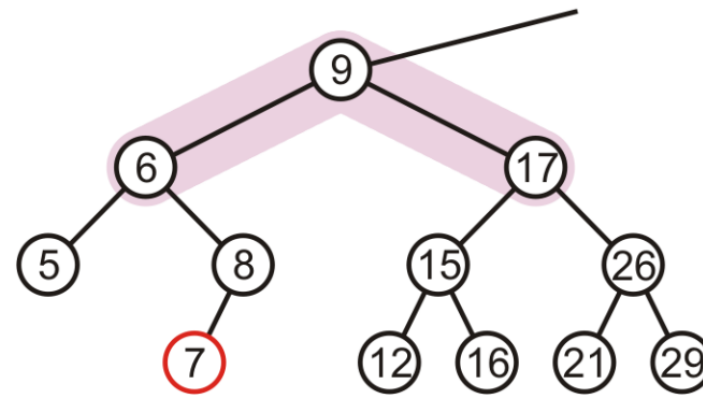
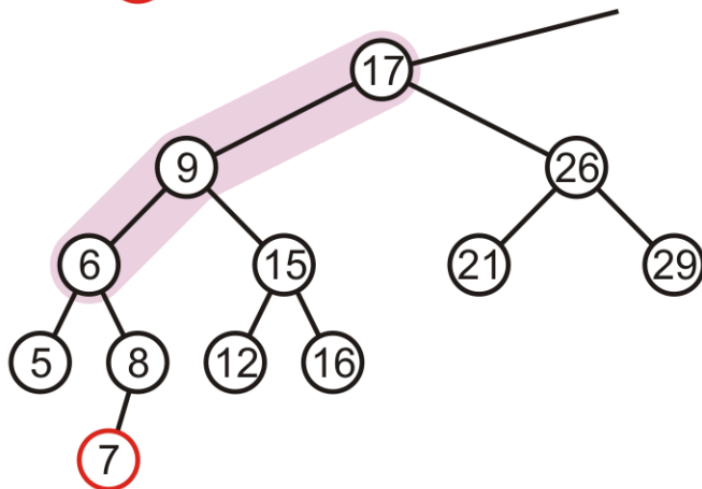
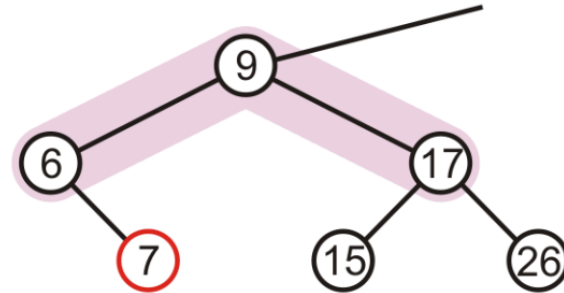
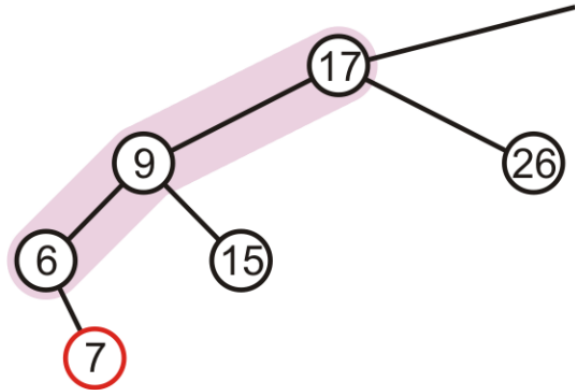
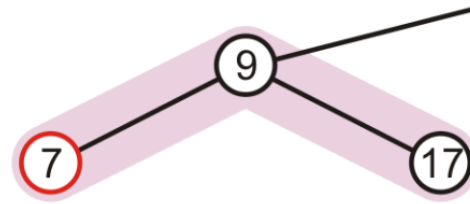
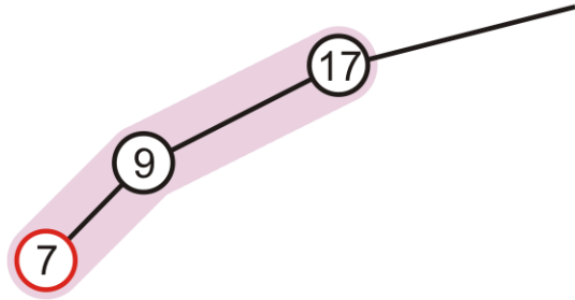

Maintaining Balance: Case 2

Alternatively, consider the insertion of c where $b < c < f$ into our original tree

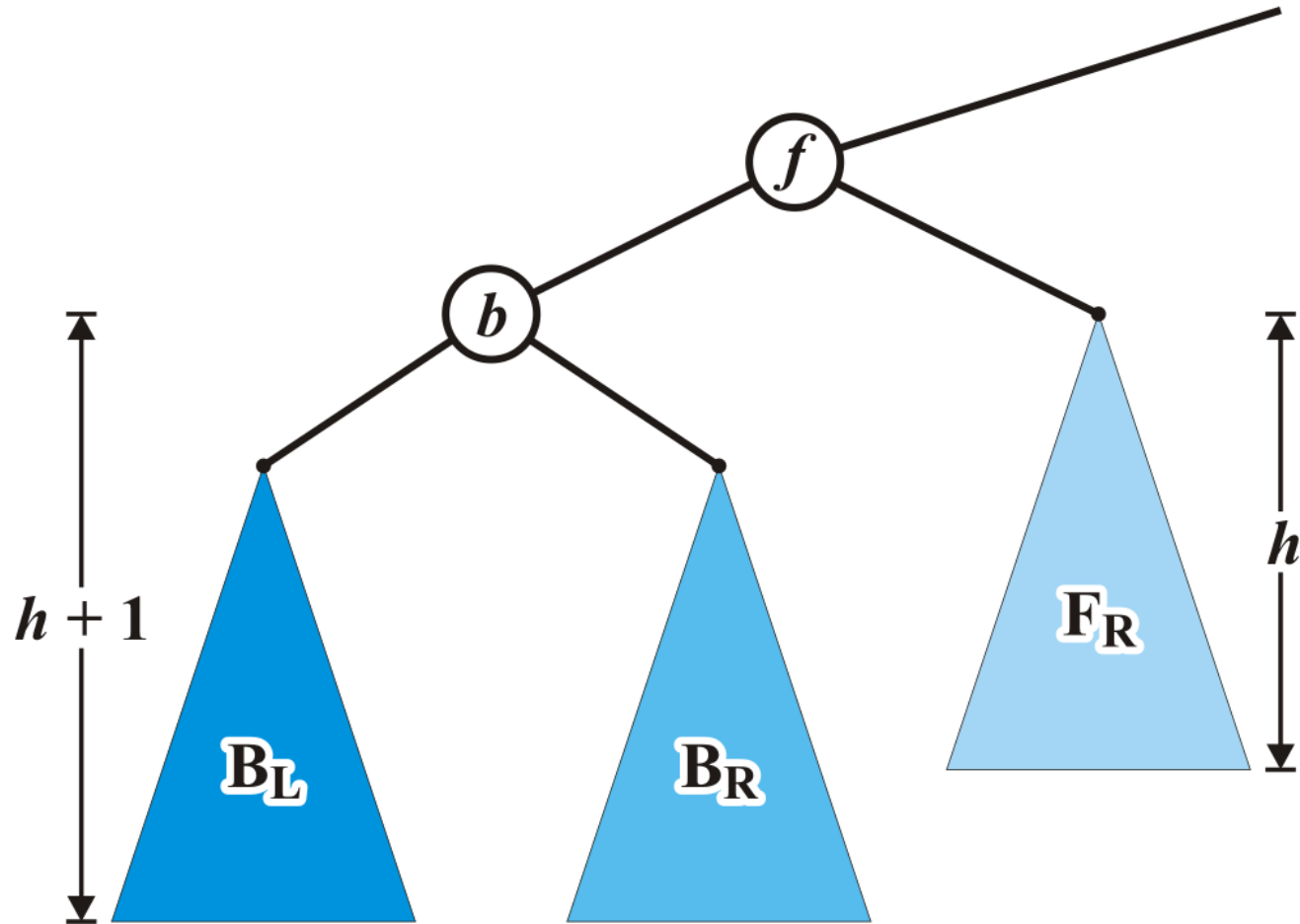

Maintaining Balance: Case 2

Assume that the insertion of c increases the height of B_R

- Once again, f becomes unbalanced

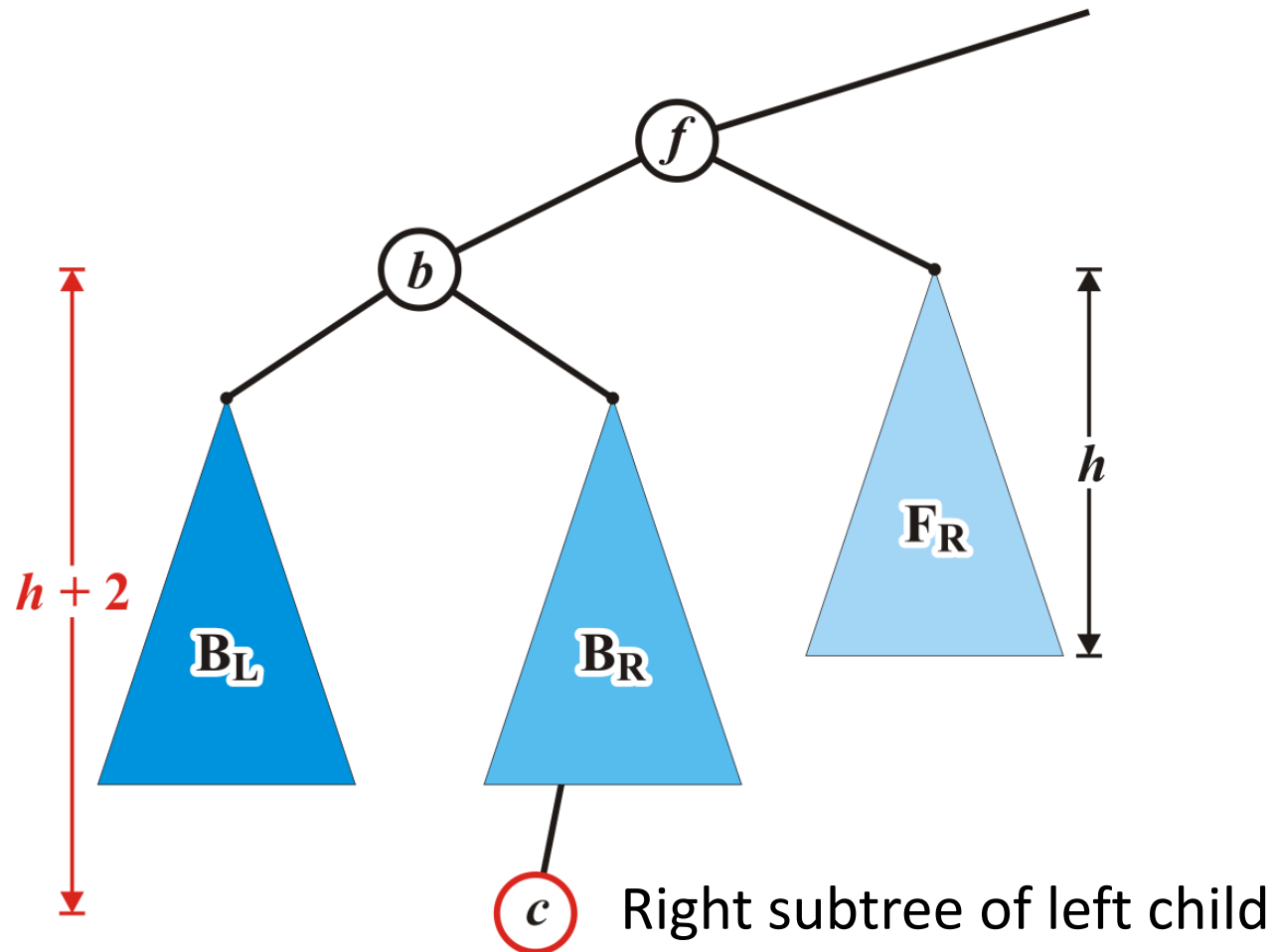

Maintaining Balance: Case 2

Here are examples of when the insertion of 14 may cause this situation when $h = -1, 0,$ and 1

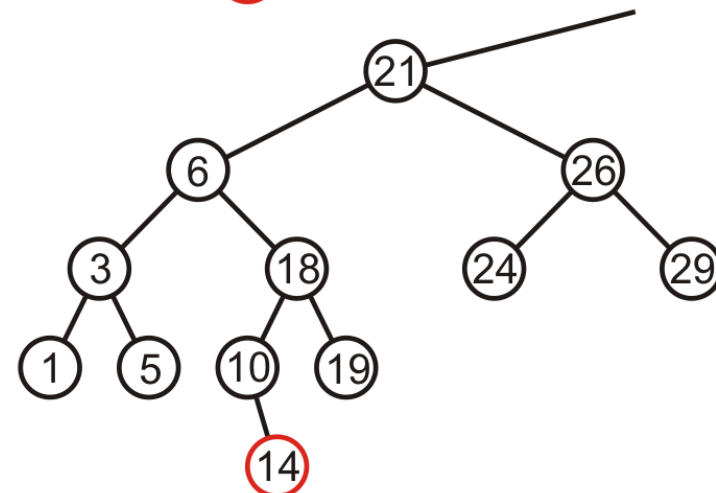
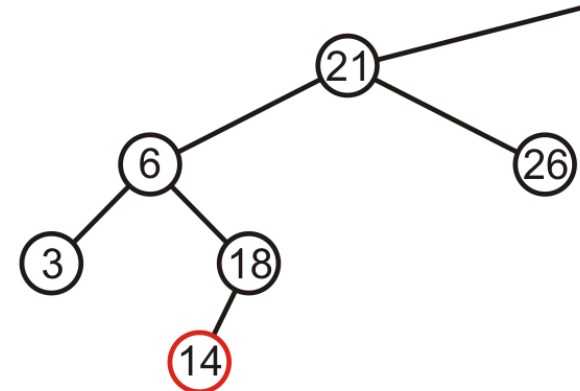
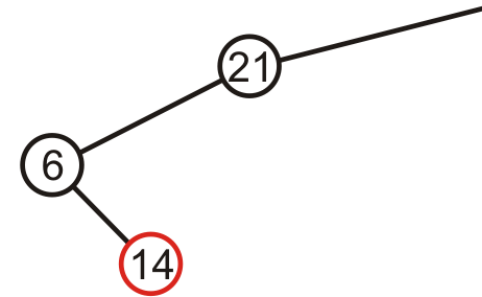
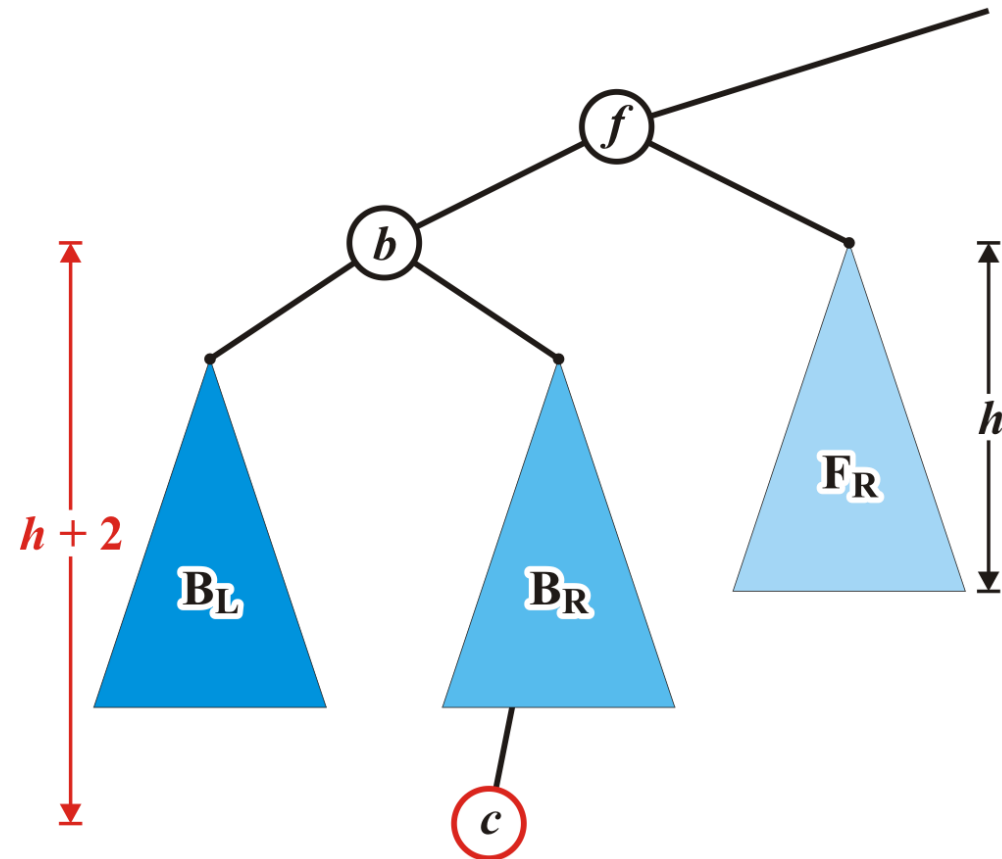

Maintaining Balance: Case 2

Unfortunately, the previous correction does not fix the imbalance at the root of this sub-tree: the new root, b , remains unbalanced

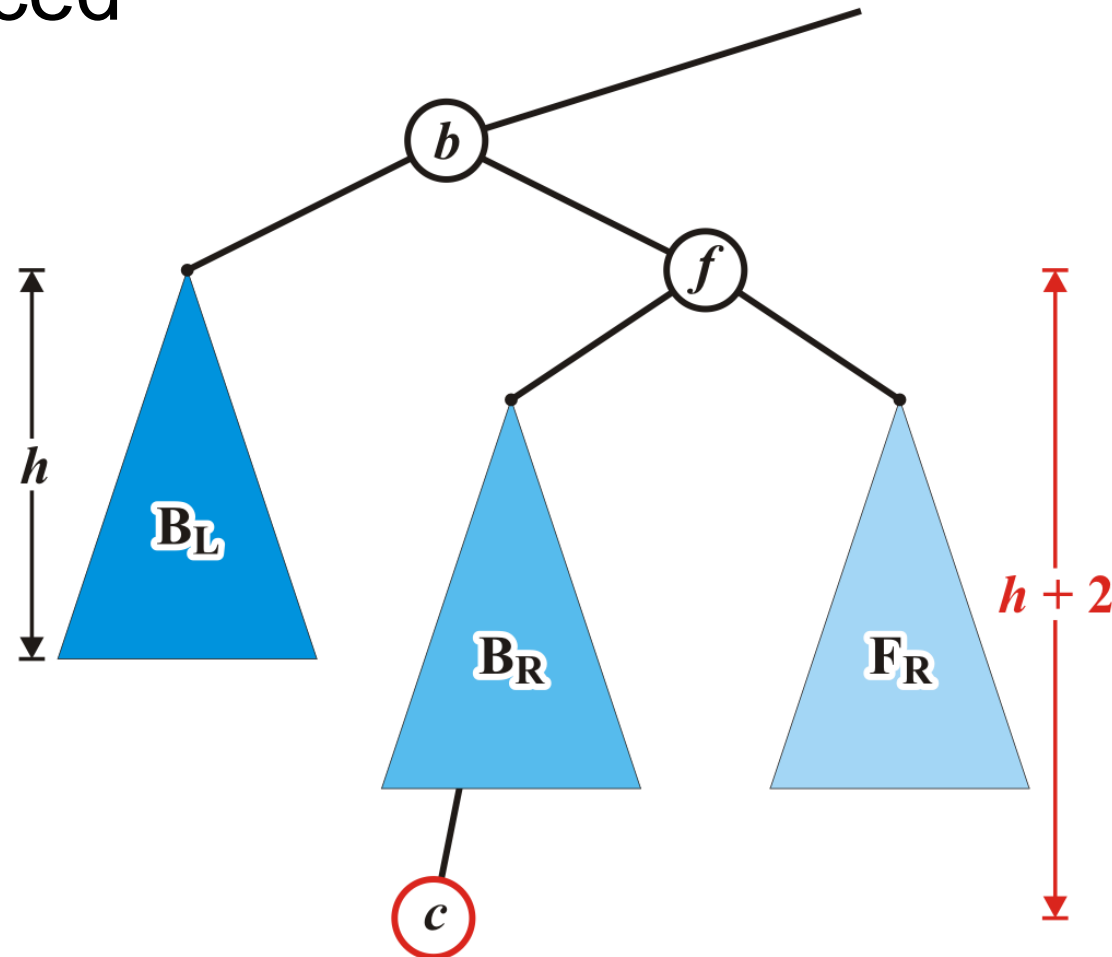

Maintaining Balance: Case 2

In our three sample cases with $h = -1, 0,$ and $1,$ doing the same thing as before results in a tree that is still unbalanced...

- The imbalance is just shifted to the other side

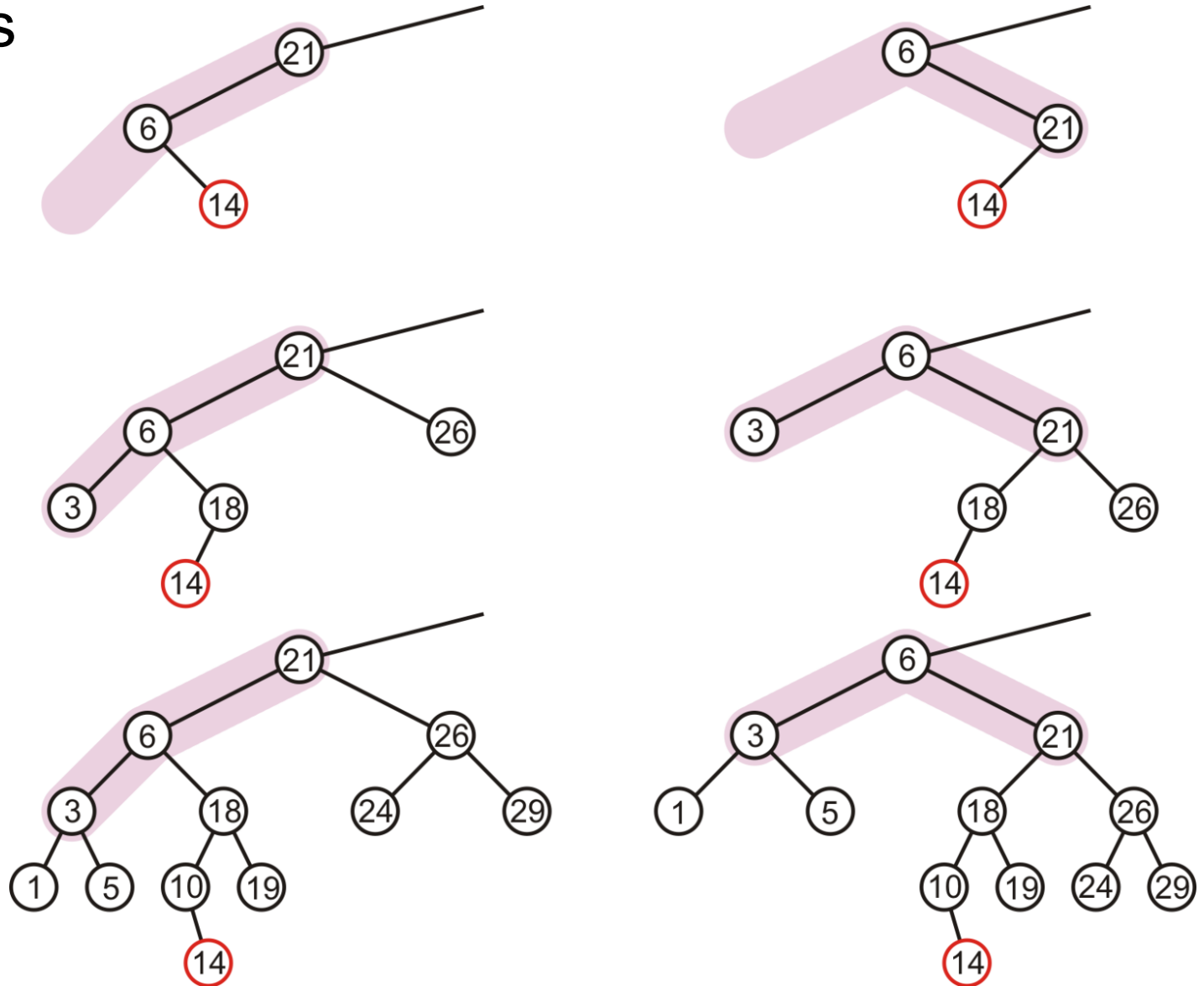

Maintaining Balance: Case 2

Lets start over ...

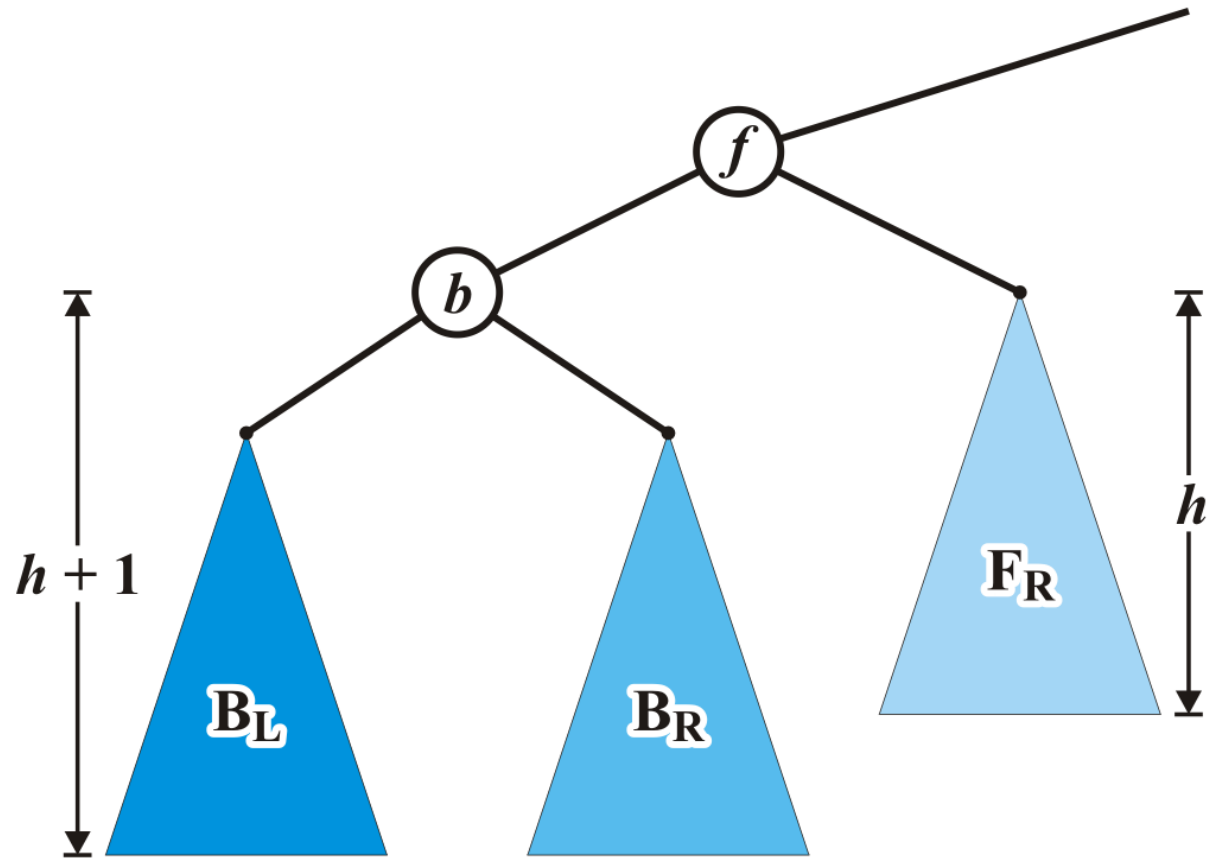

Maintaining Balance: Case 2

Re-label the tree by dividing the left subtree of f into a tree rooted at d with two subtrees of height $h - 1$

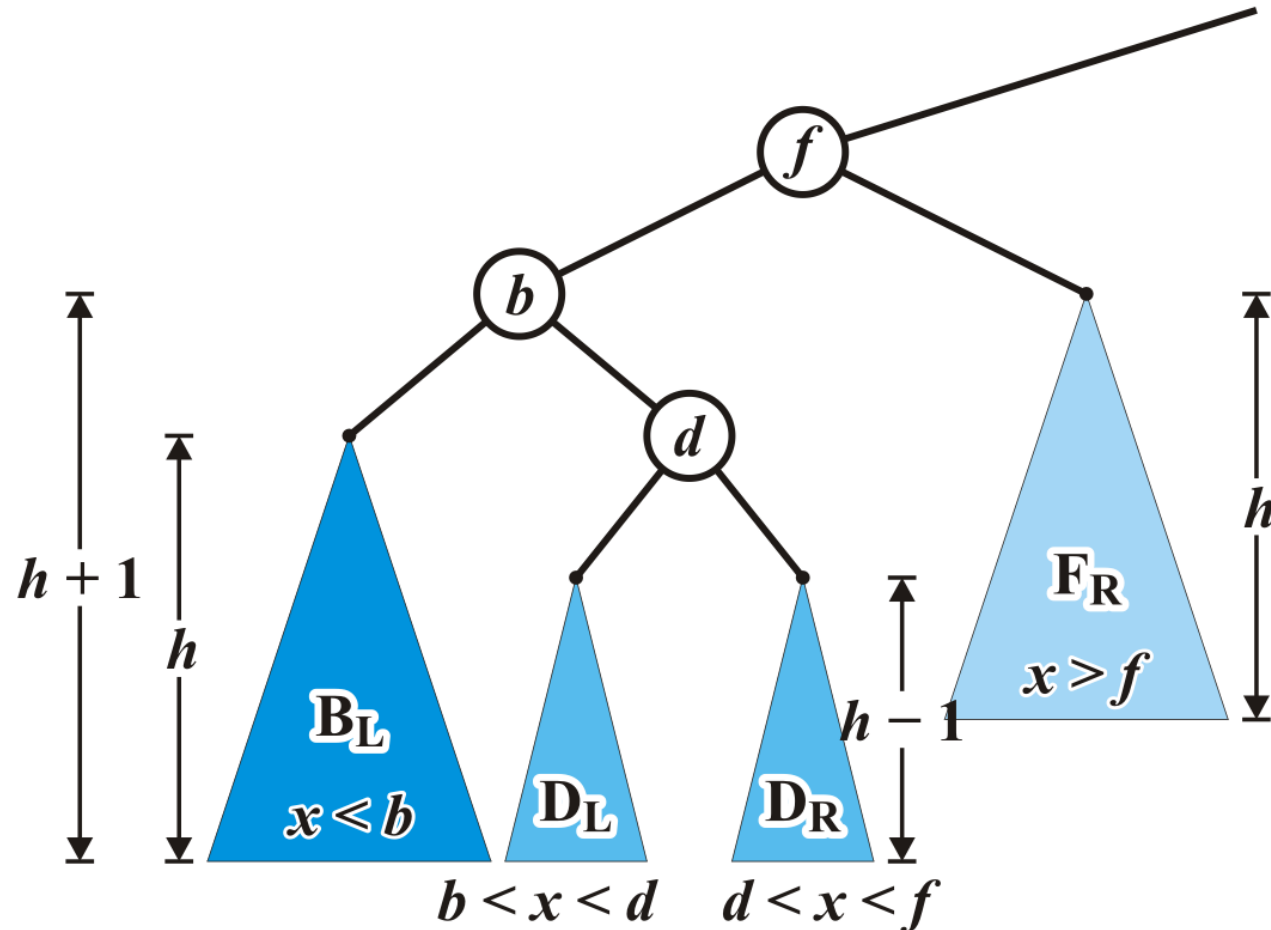

Maintaining Balance: Case 2

Now an insertion causes an imbalance at f

- The addition of either c or e will cause this

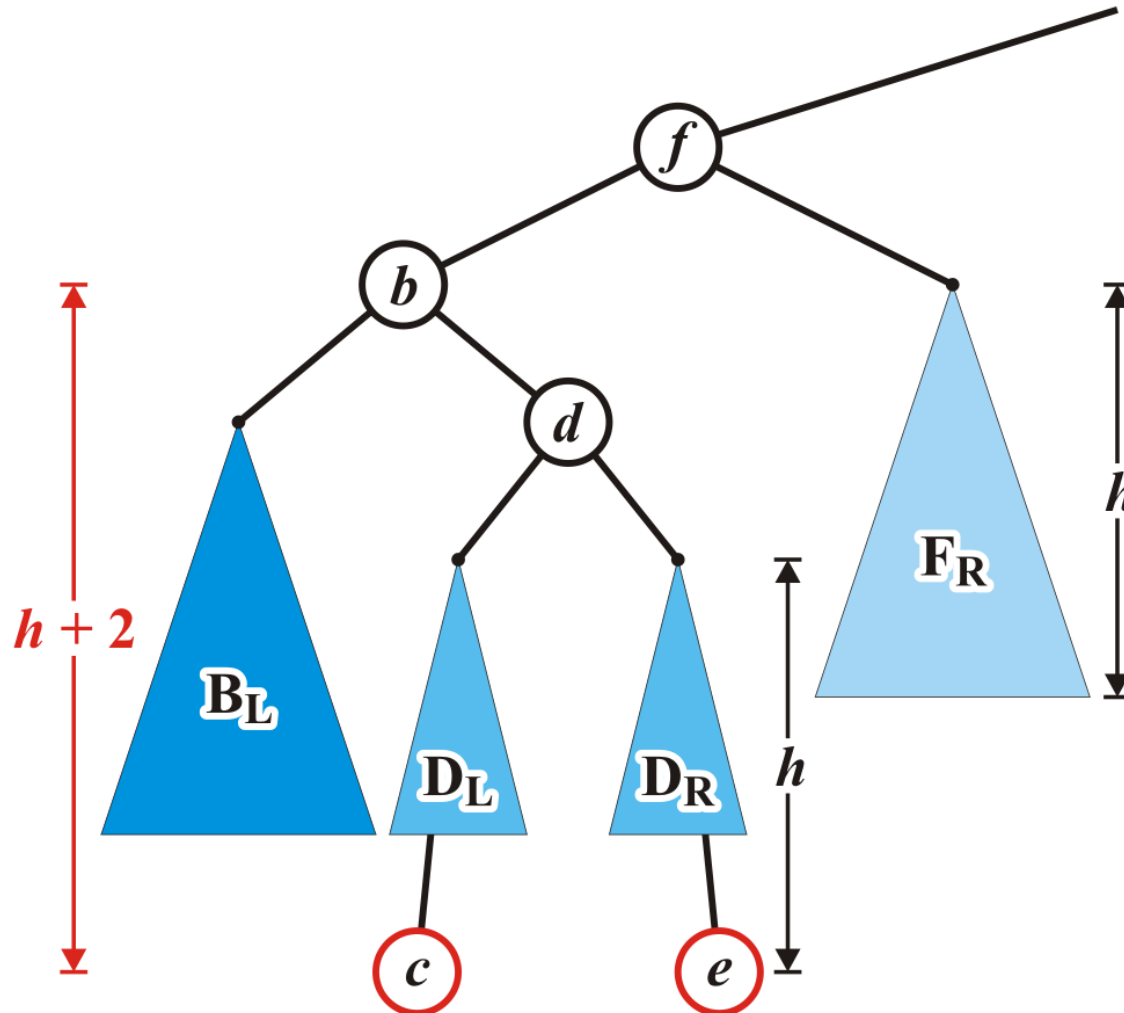

Maintaining Balance: Case 2

We will reassign the following pointers

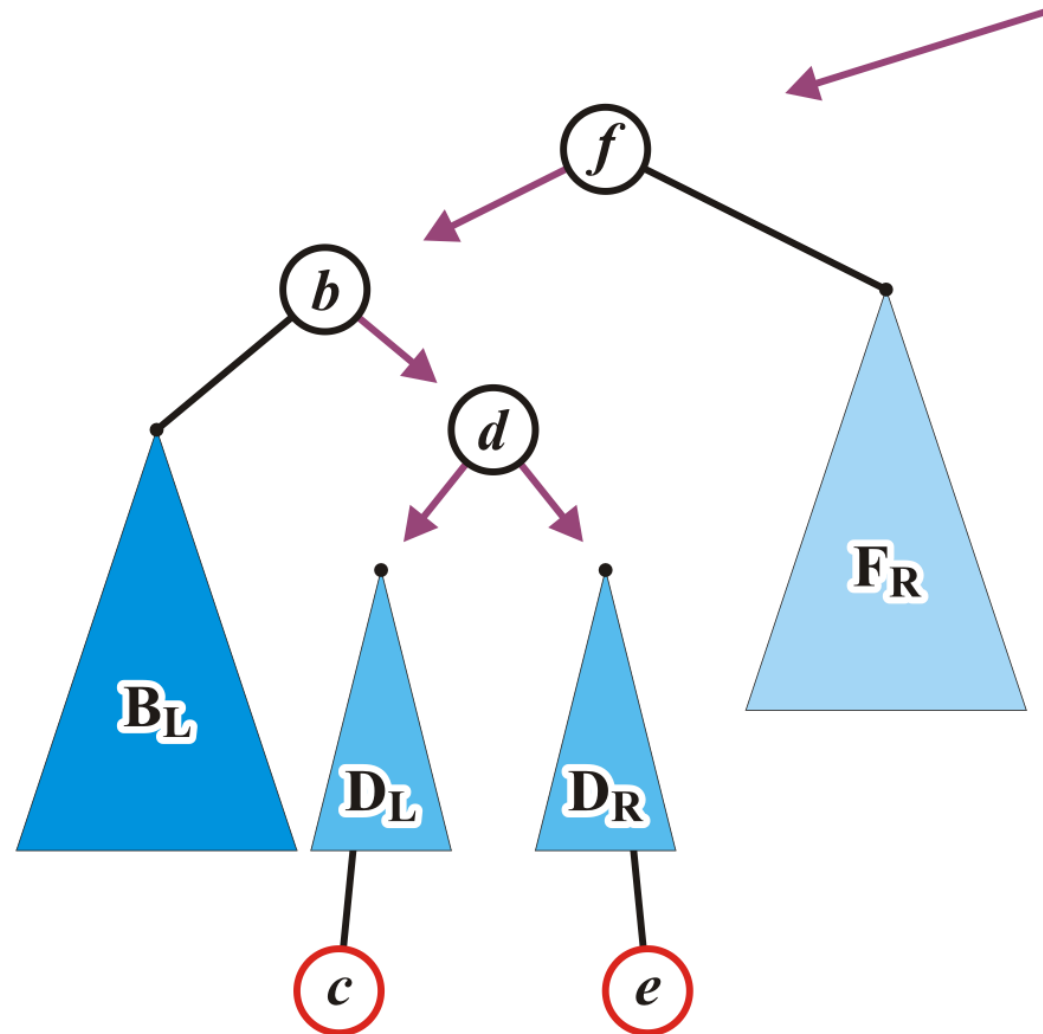

Maintaining Balance: Case 2

Specifically, we will order these three nodes as a perfect tree

- Recall the second prototypical example

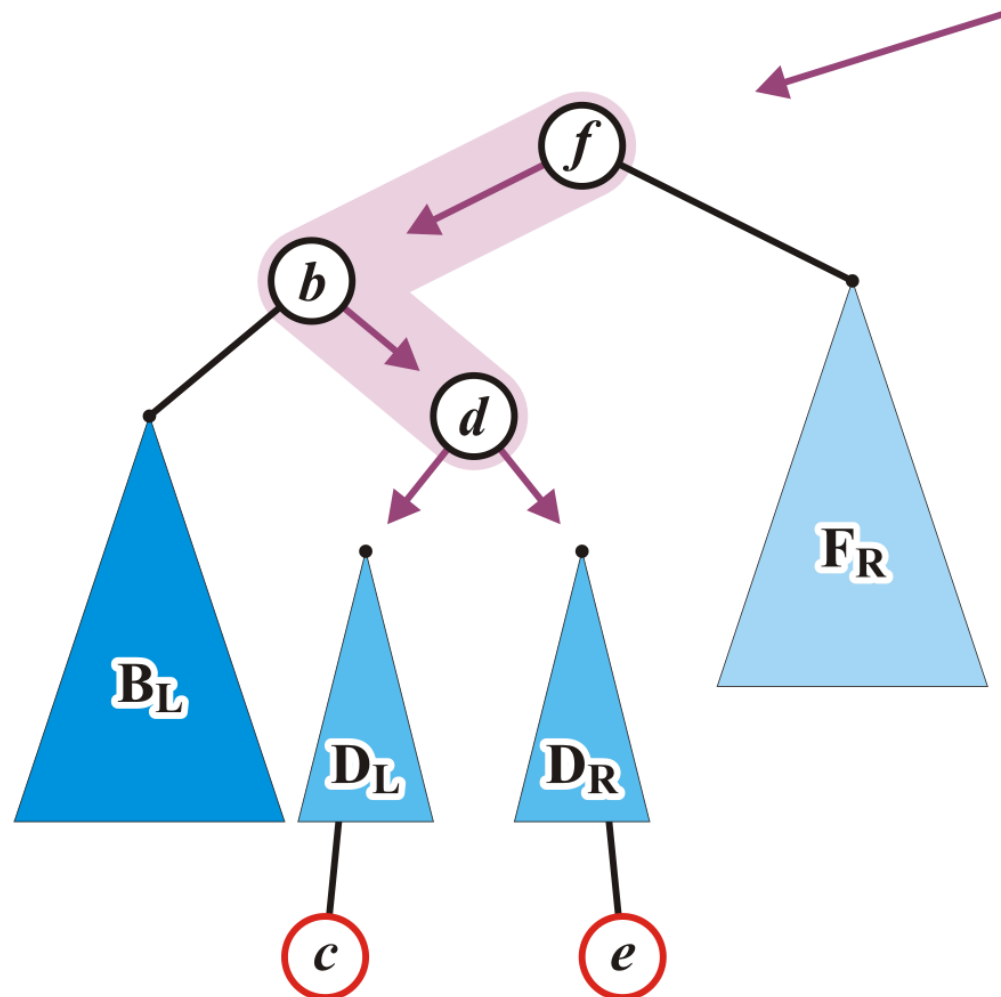

Maintaining Balance: Case 2

To achieve this, b and f will be assigned as children of the new root d

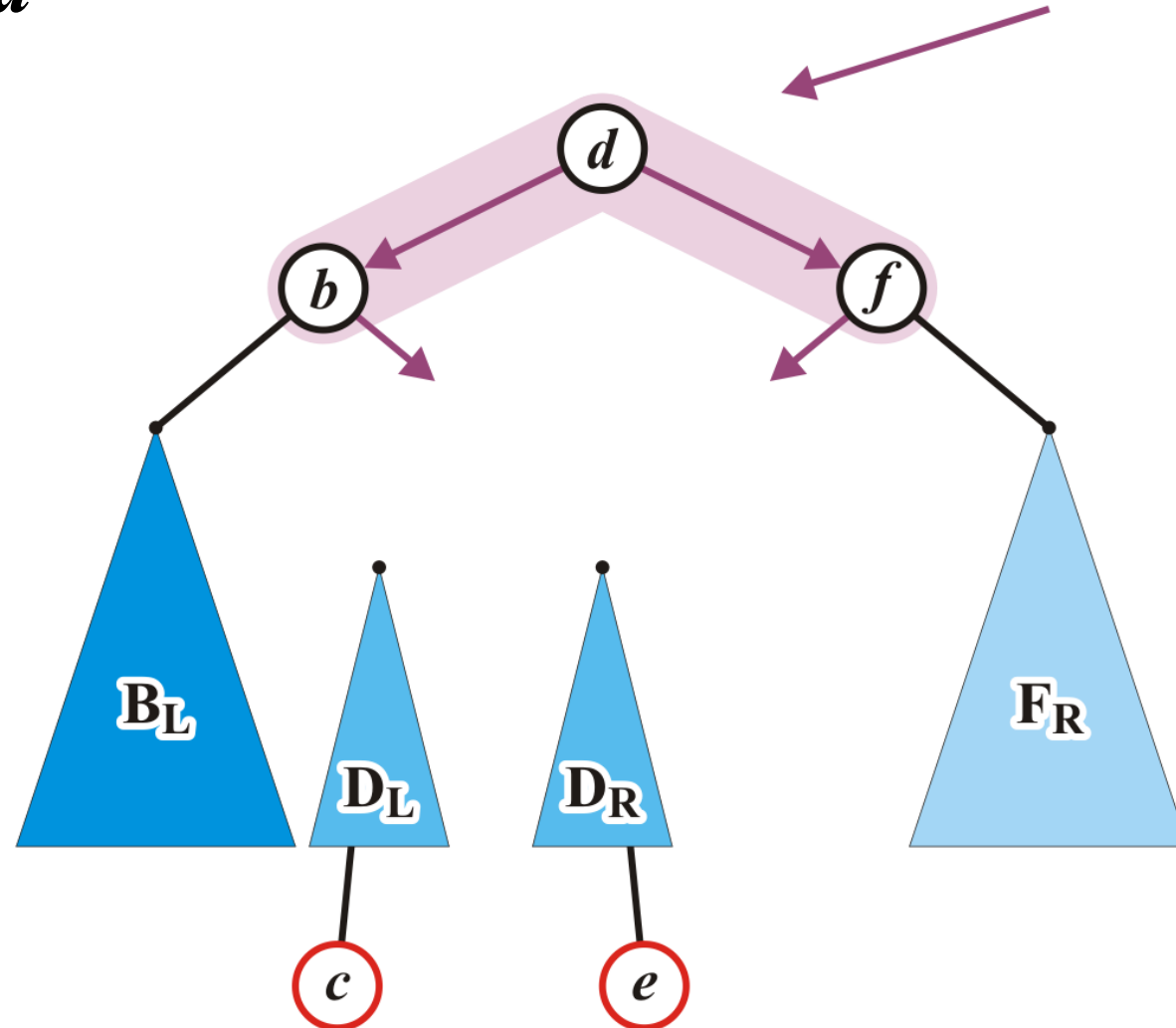

Maintaining Balance: Case 2

We also have to connect the two subtrees and original parent of f

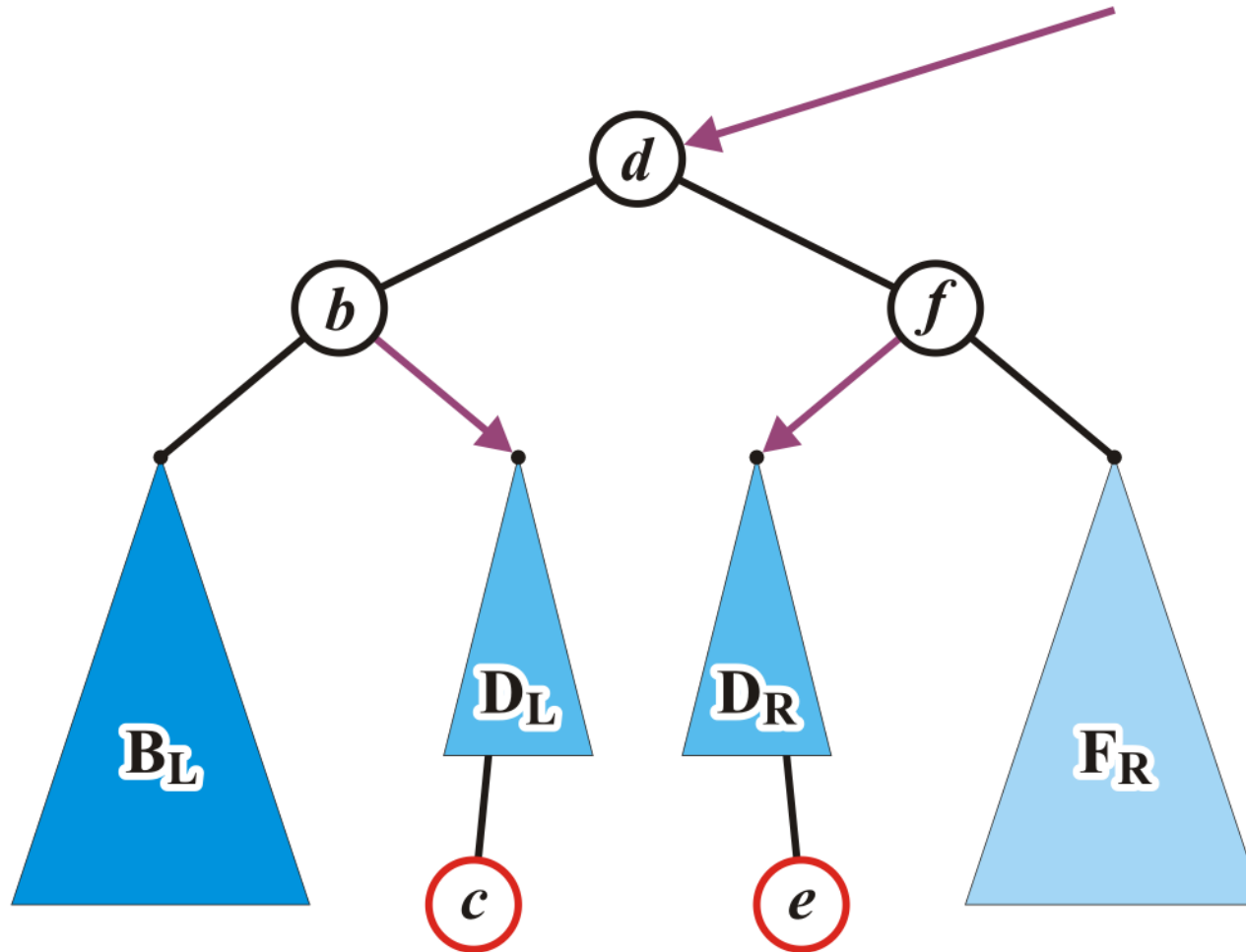

Maintaining Balance: Case 2

Now the tree rooted at d is balanced

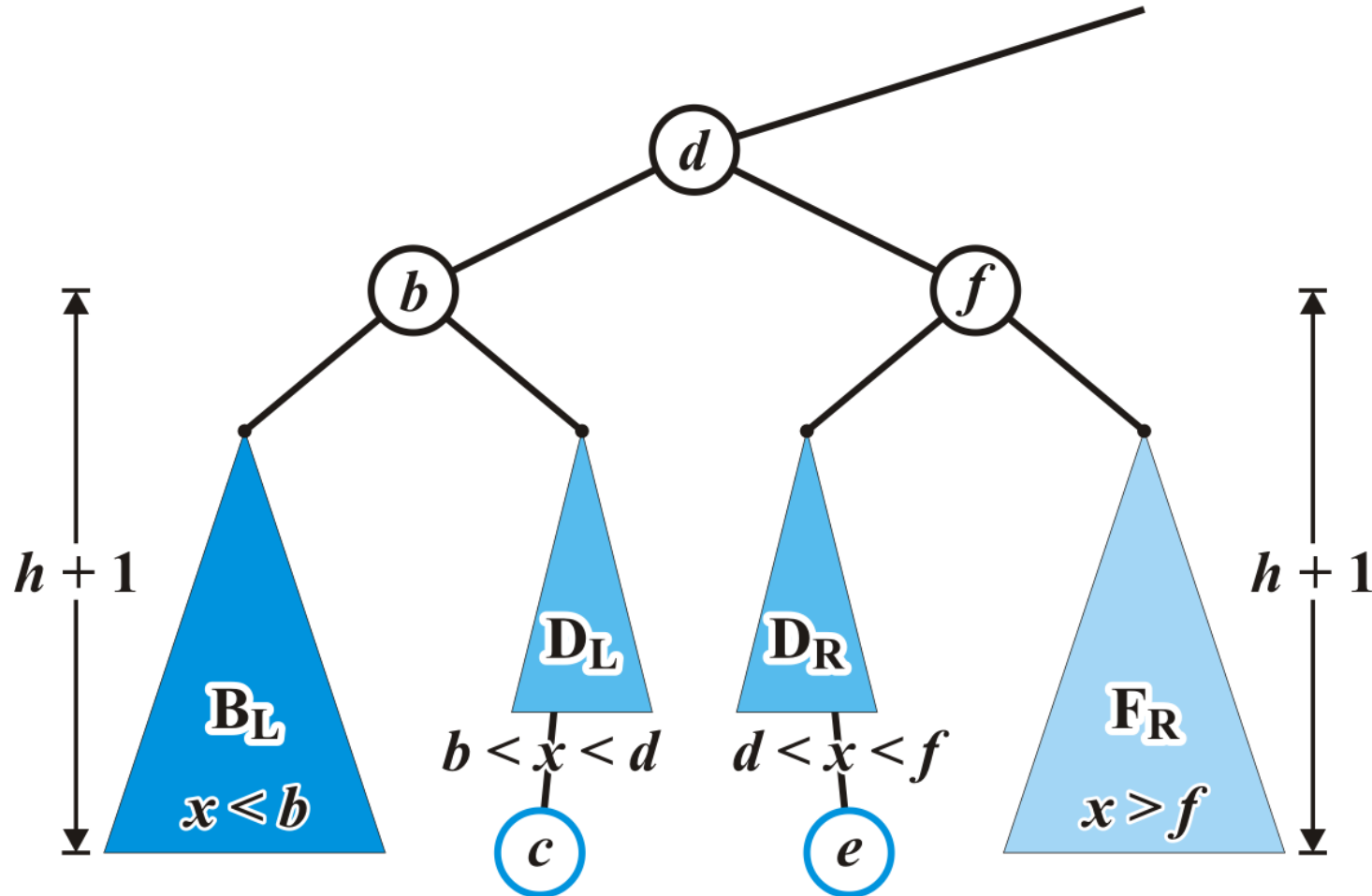

Maintaining Balance: Case 2

Again, the height of the root did not change

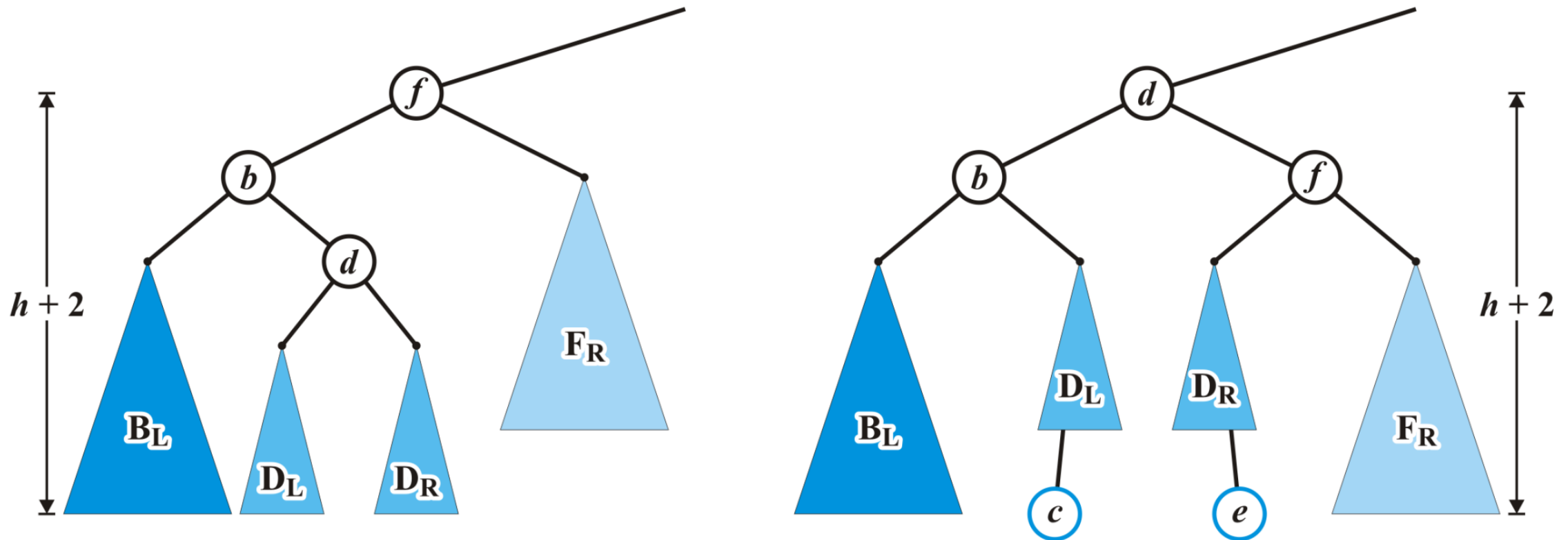

Maintaining Balance: Case 2

In our three sample cases with $h = -1, 0,$ and $1,$ the node is now balanced and the same height as the tree before the insertion

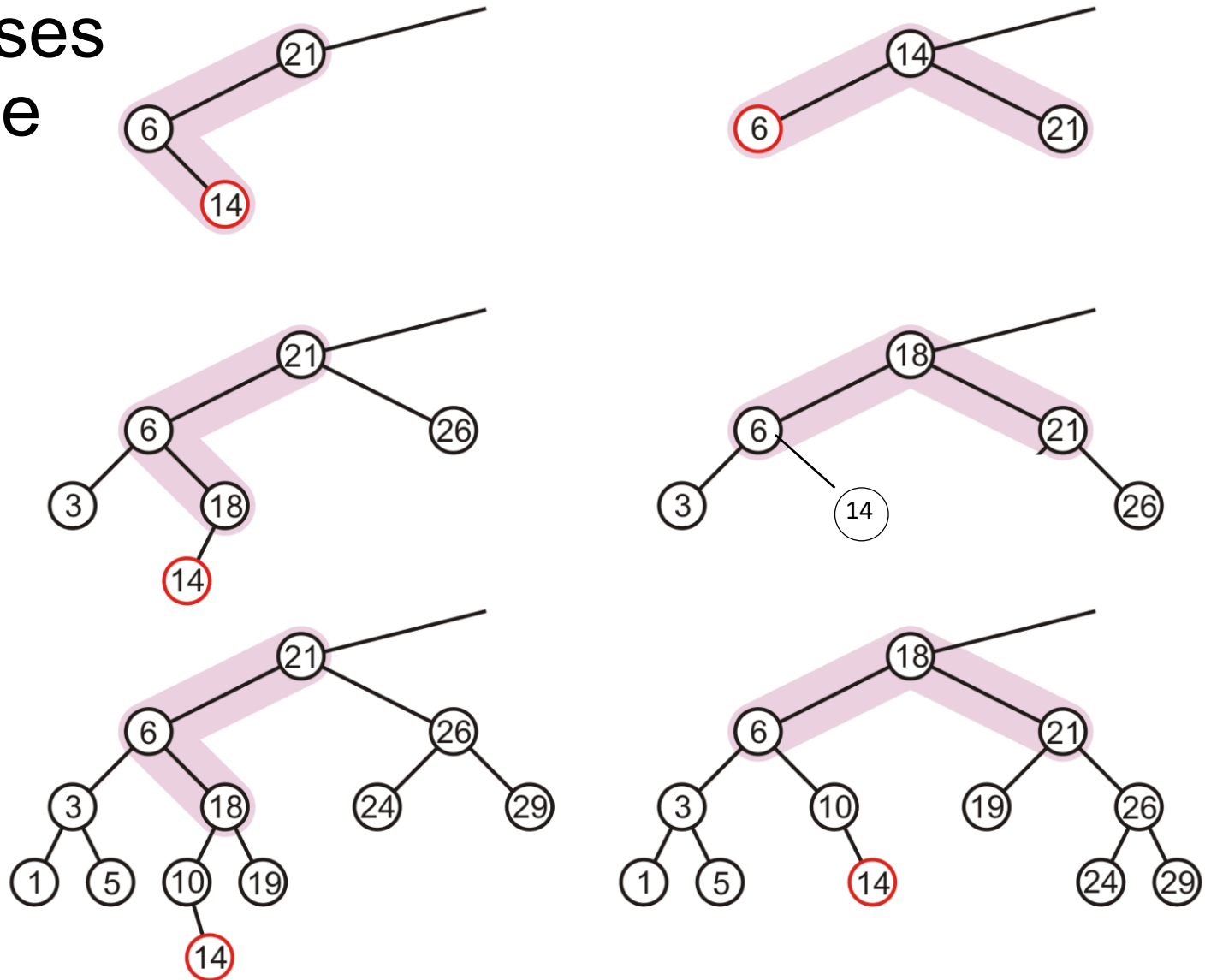

Maintaining Balance: Summary

There are two symmetric cases to those we have examined:

- Insertions into the right-right sub-tree

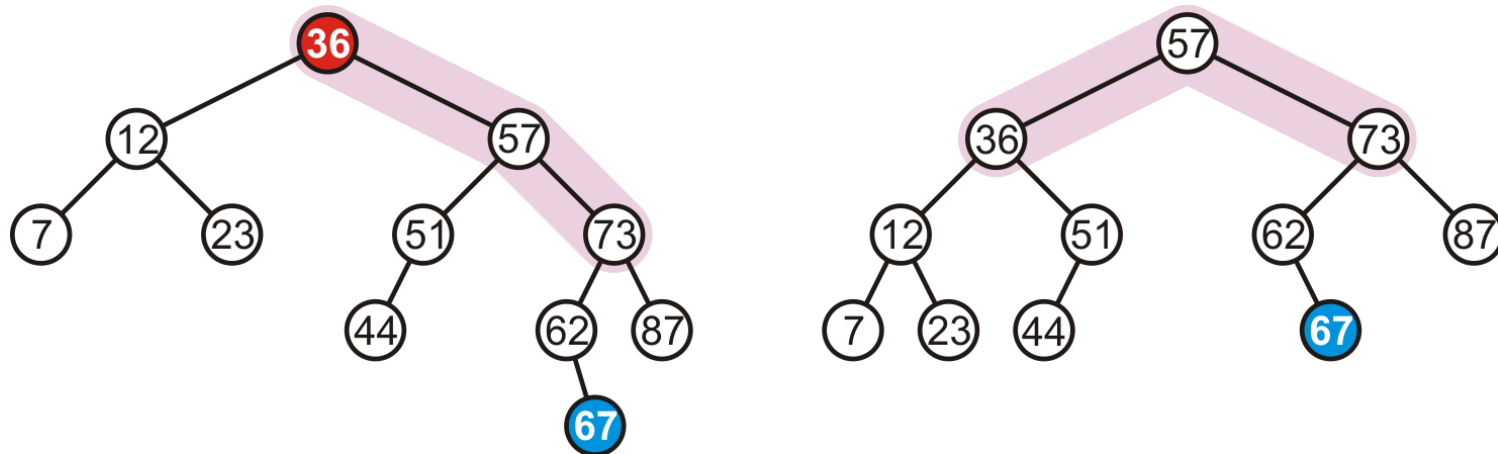

-- Insertions into either the right-left sub-tree

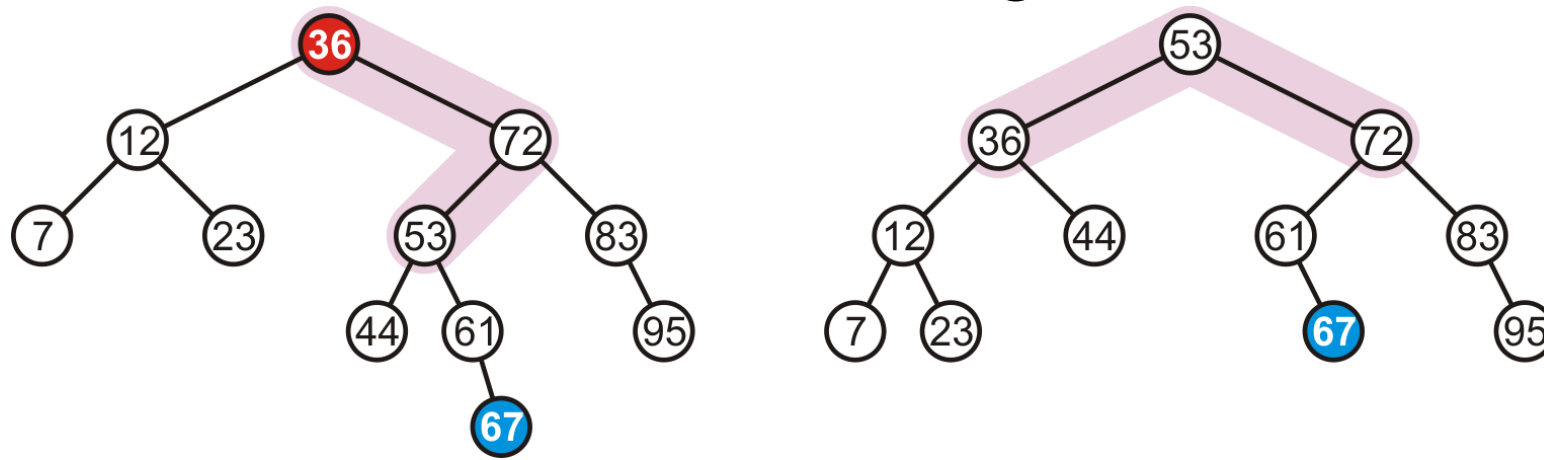

More Examples: Insertion

Consider this AVL tree

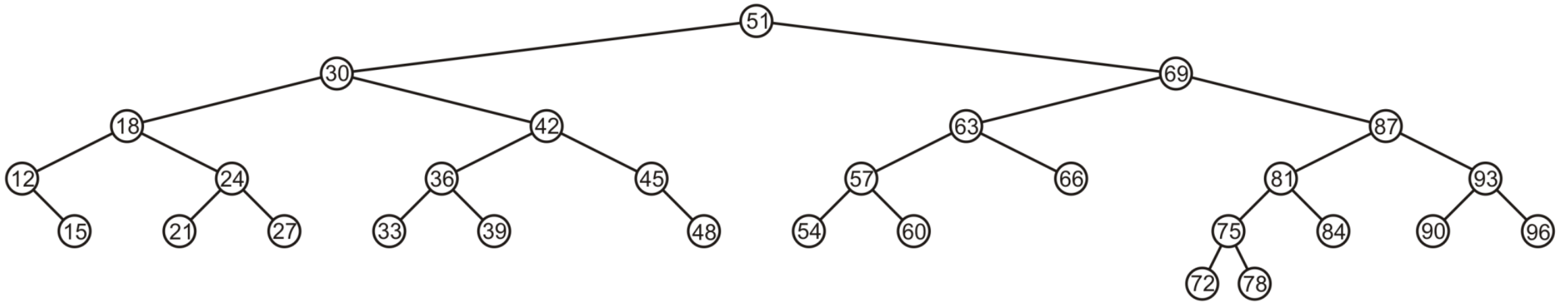

Insertion

Insert 73

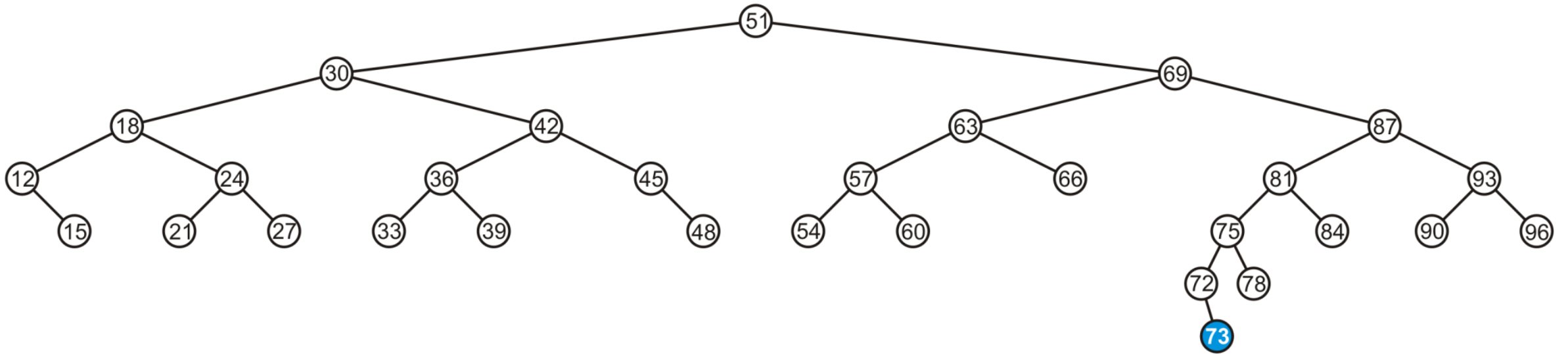

Insertion

The node 81 is unbalanced

- A left-left imbalance

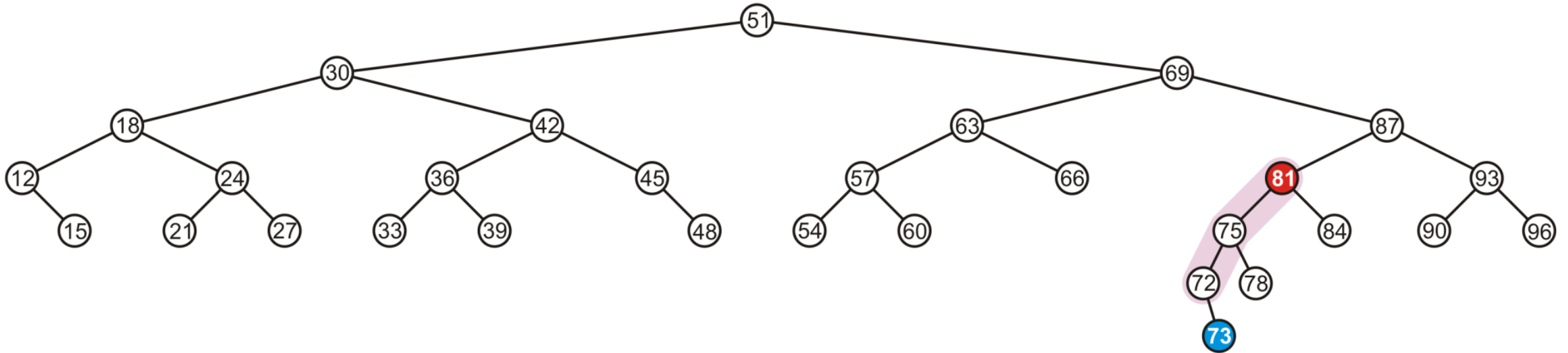

Insertion

The node 81 is unbalanced

- A left-left imbalance

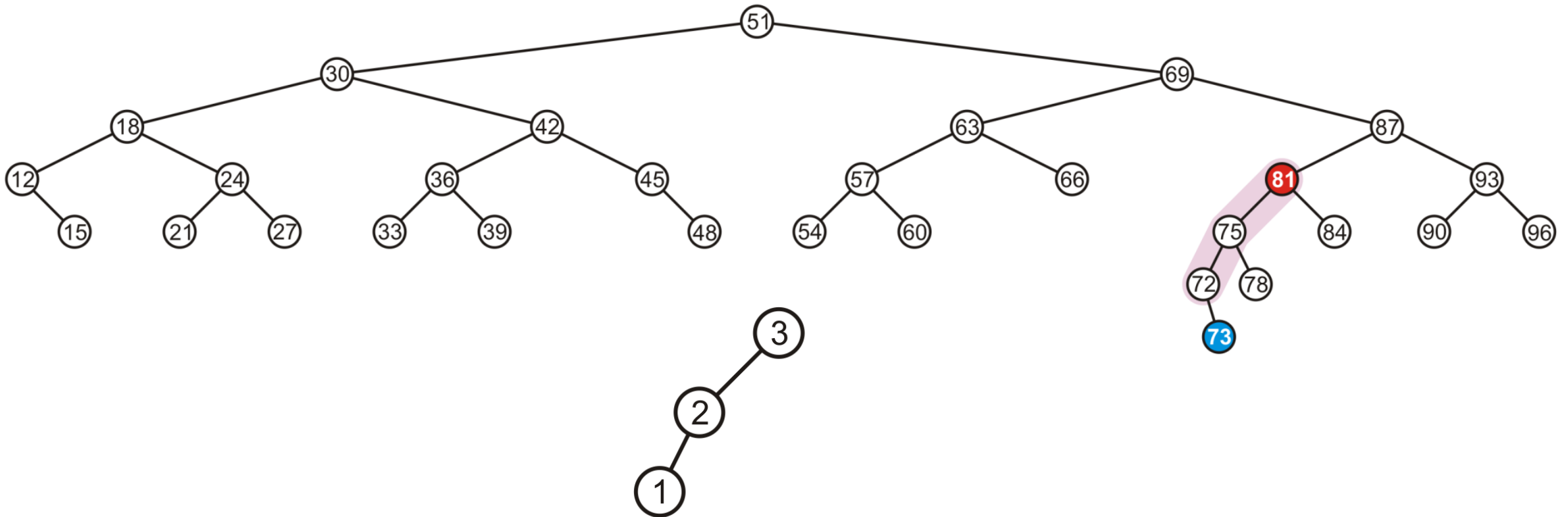

Insertion

The node 81 is unbalanced

- A left-left imbalance

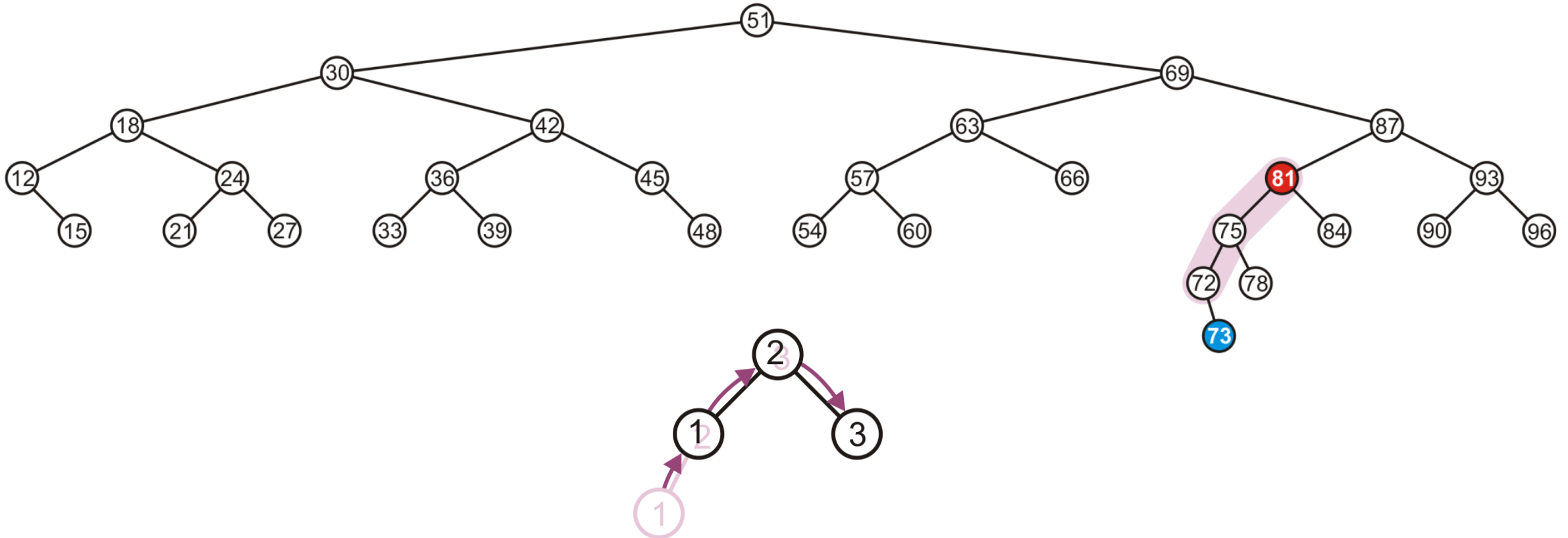

Insertion

The node 81 is unbalanced

- A left-left imbalance
- Promote the intermediate node to the imbalanced node
- 75 is that node

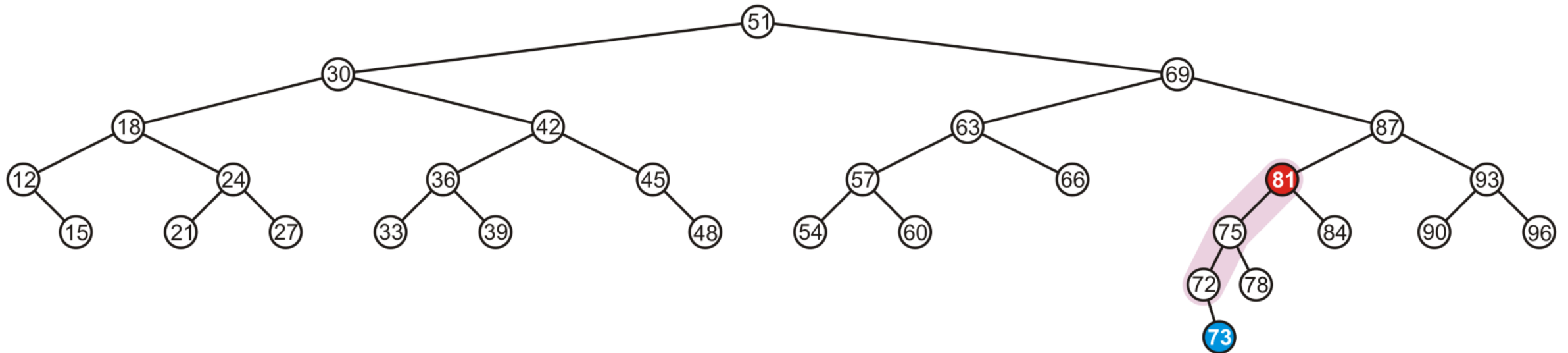

Insertion

The node 81 is unbalanced

- A left-left imbalance
- Promote the intermediate node to the imbalanced node
- 75 is that node

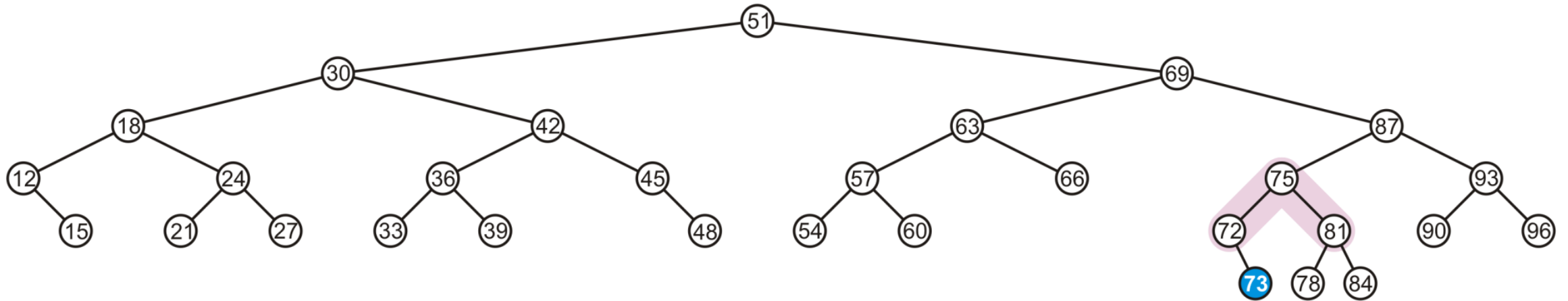

Insertion

The tree is AVL balanced

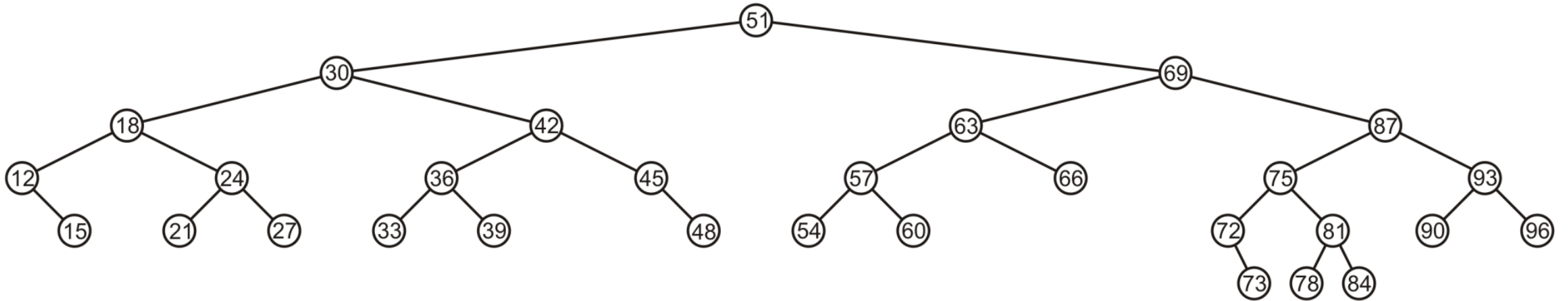

Insertion

Insert 77

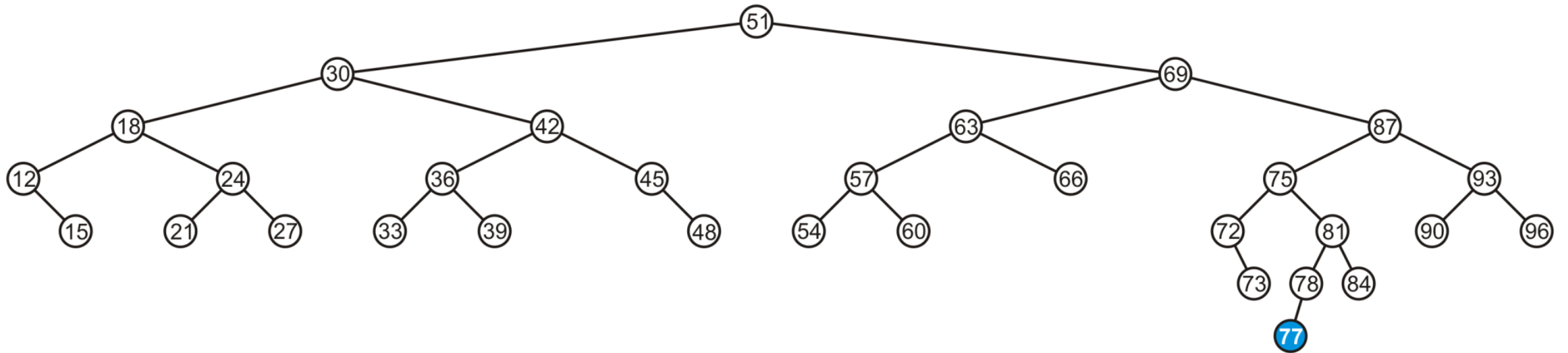

Insertion

The node 87 is unbalanced

- A left-right imbalance

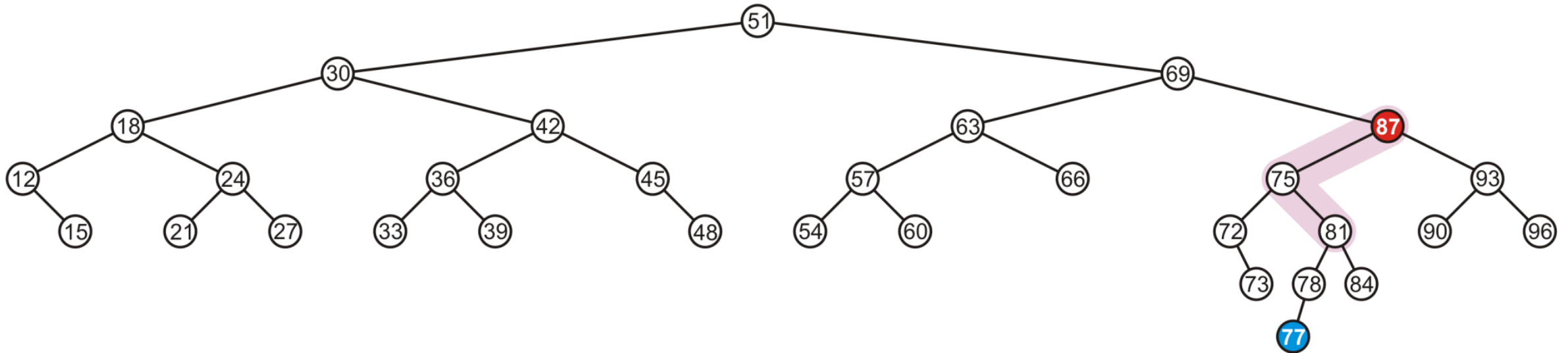

Insertion

The node 87 is unbalanced

- A left-right imbalance

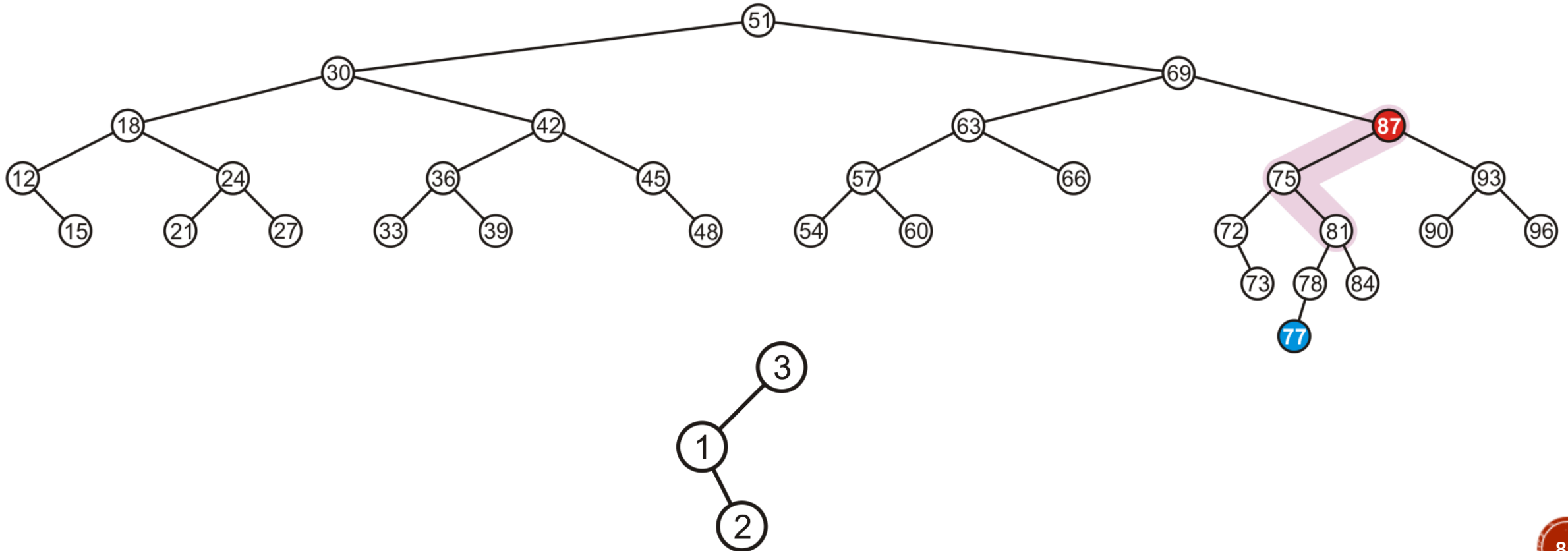

Insertion

The node 87 is unbalanced

- A left-right imbalance

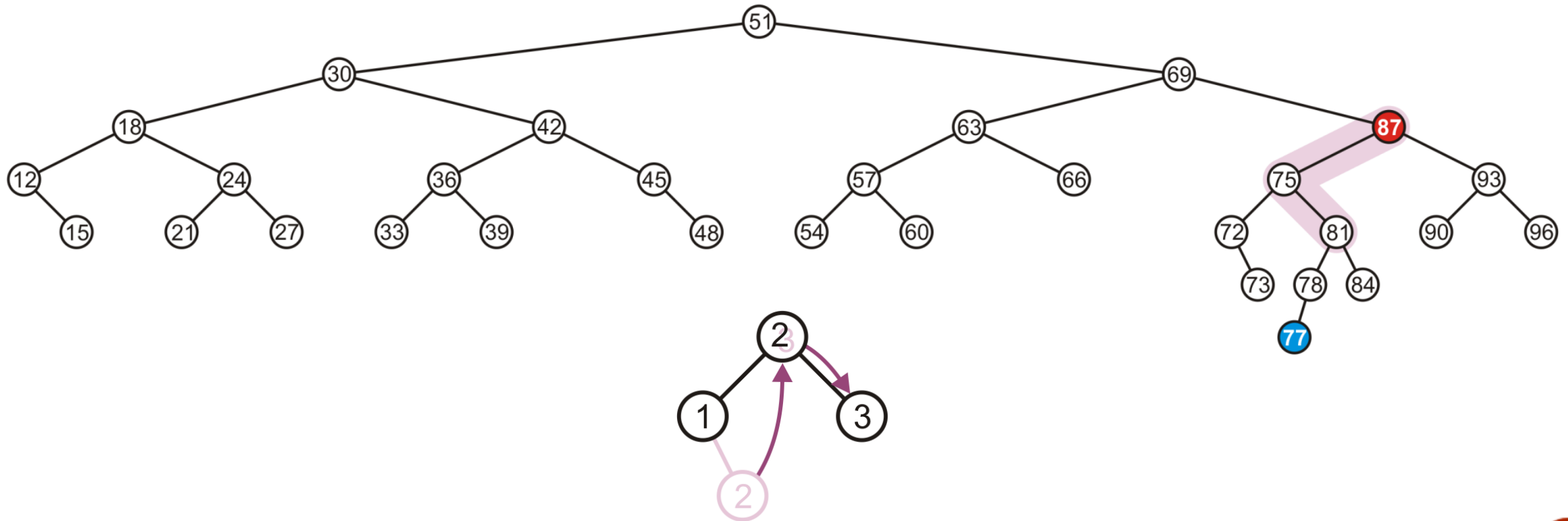

Insertion

The node 87 is unbalanced

- A left-right imbalance
- Promote the intermediate node to the imbalanced node
- 81 is that value

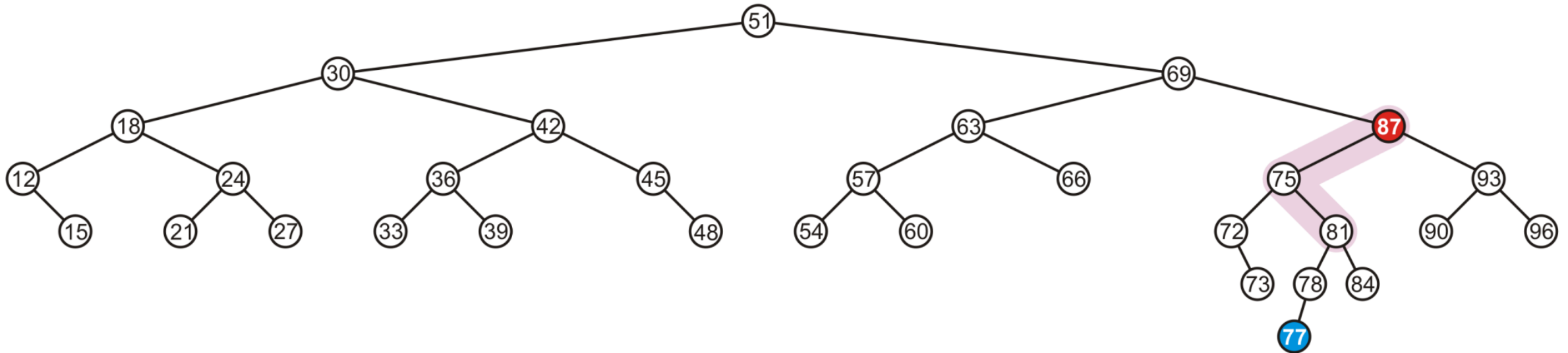

Insertion

The node 87 is unbalanced

- A left-right imbalance
- Promote the intermediate node to the imbalanced node
- 81 is that value

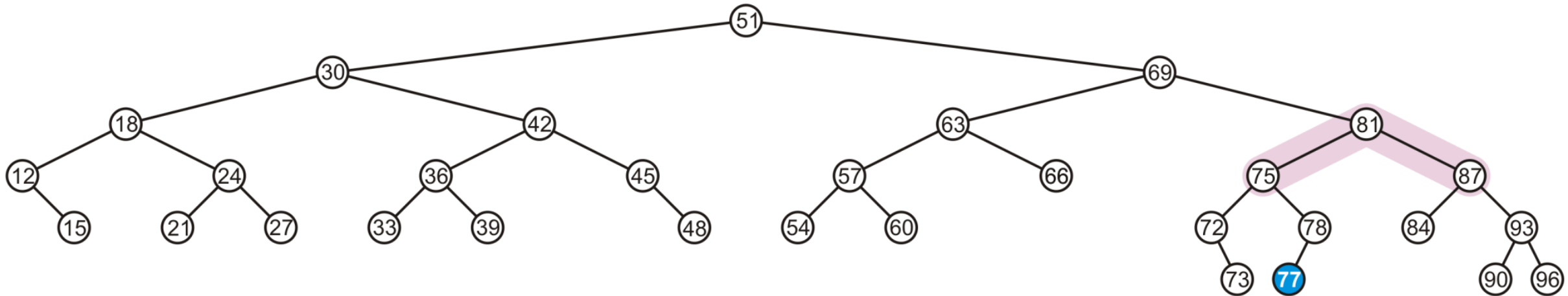

Insertion

The tree is balanced

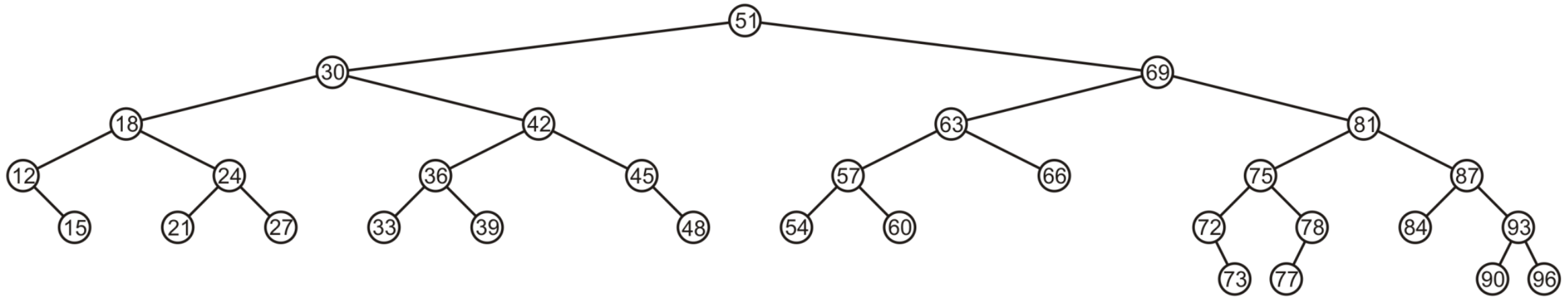

Insertion

Insert 76

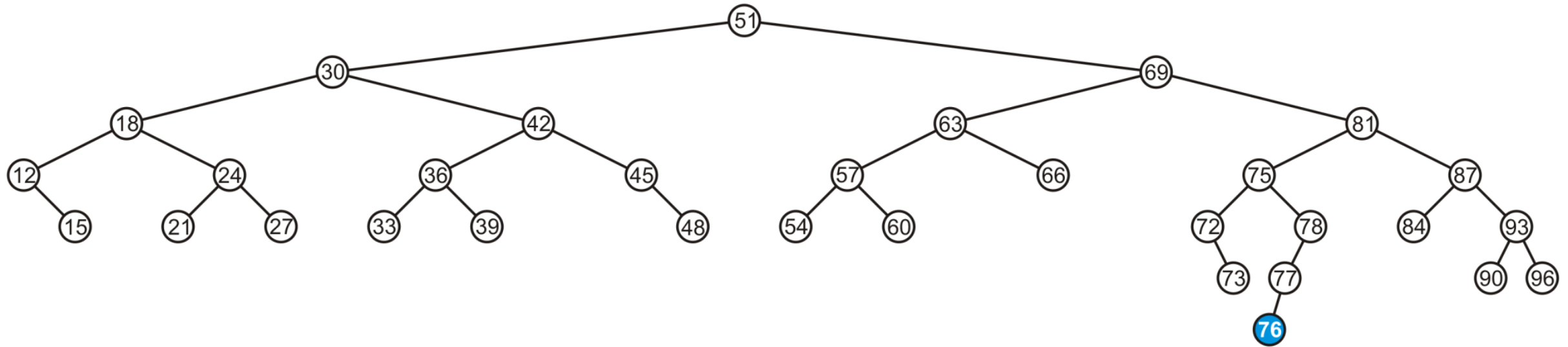

Insertion

The node 78 is unbalanced

- A left-left imbalance

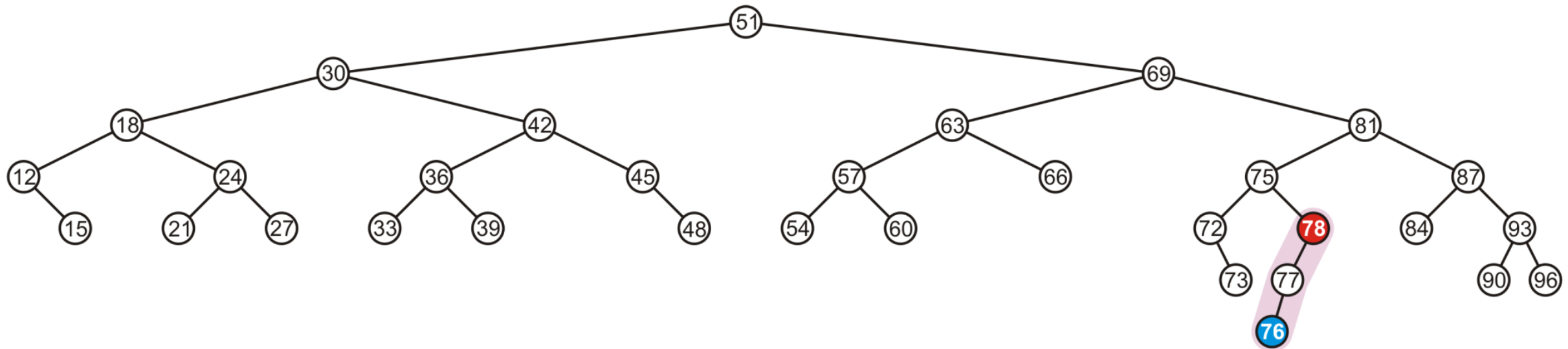

Insertion

The node 78 is unbalanced

- Promote 77

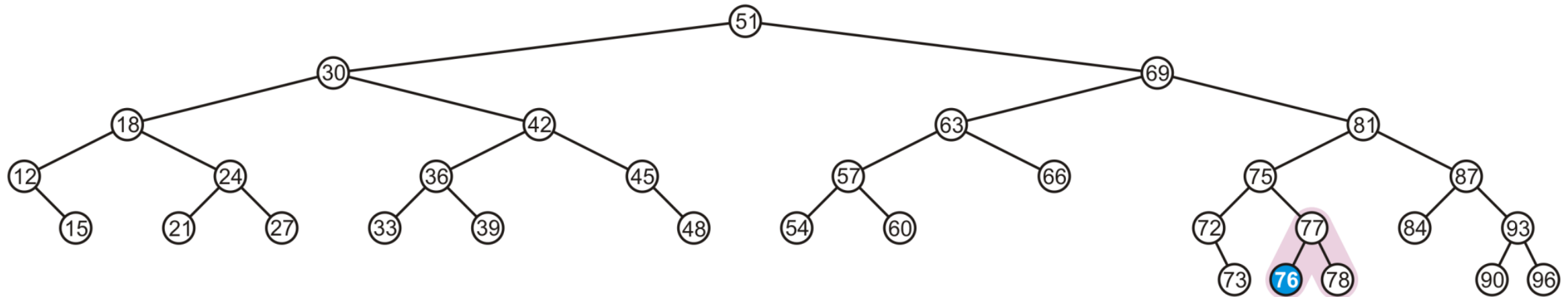

Insertion

Again, balanced

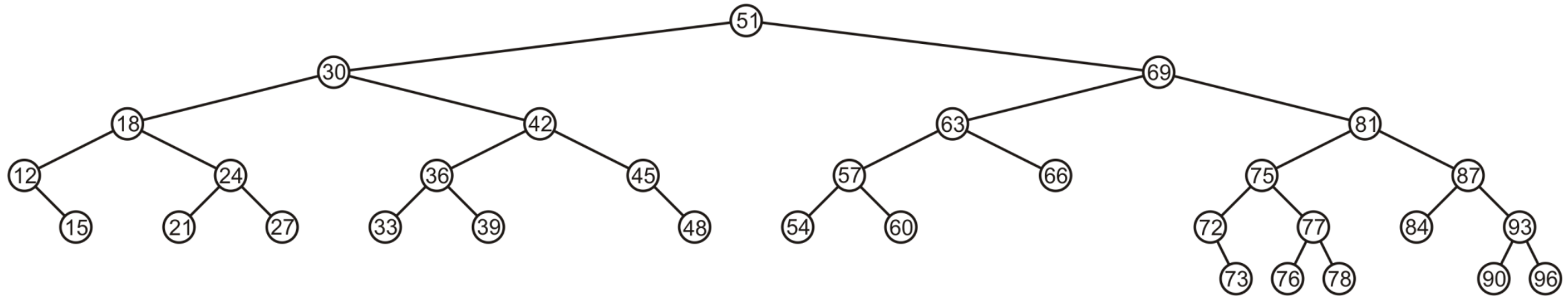

Insertion

Insert 80

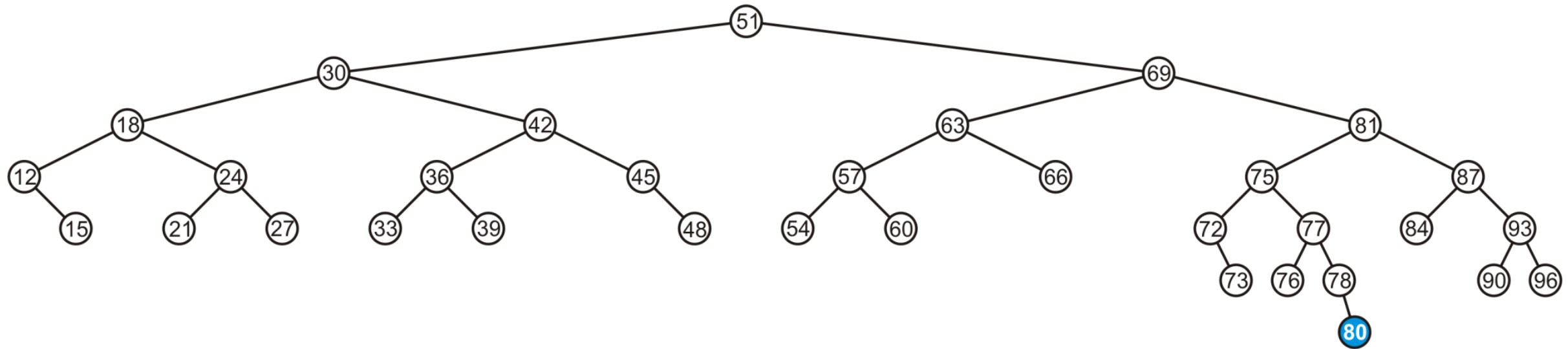

Insertion

The node 69 is unbalanced

- A right-left imbalance
- Promote the intermediate node to the imbalanced node

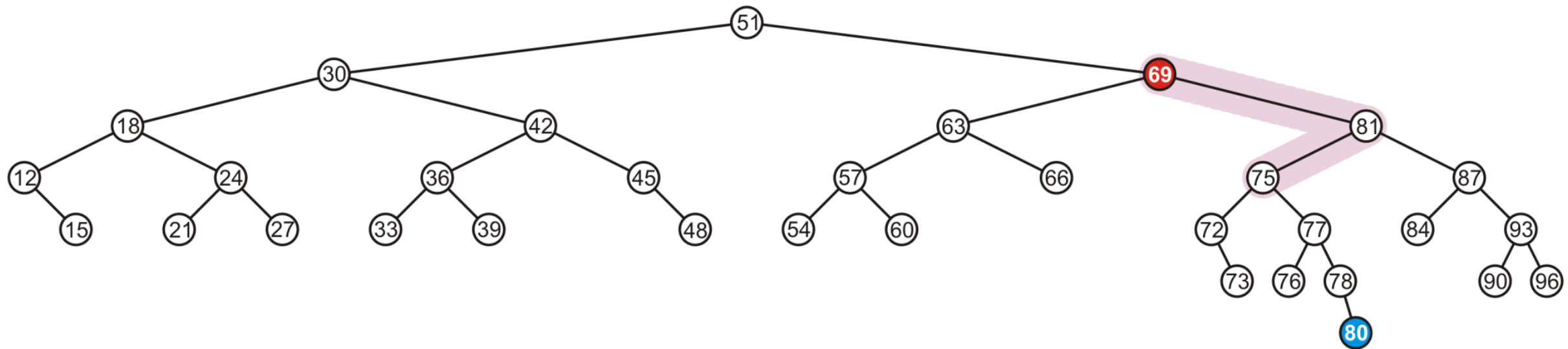

Insertion

The node 69 is unbalanced

- A left-right imbalance
- Promote the intermediate node to the imbalanced node
- 75 is that value

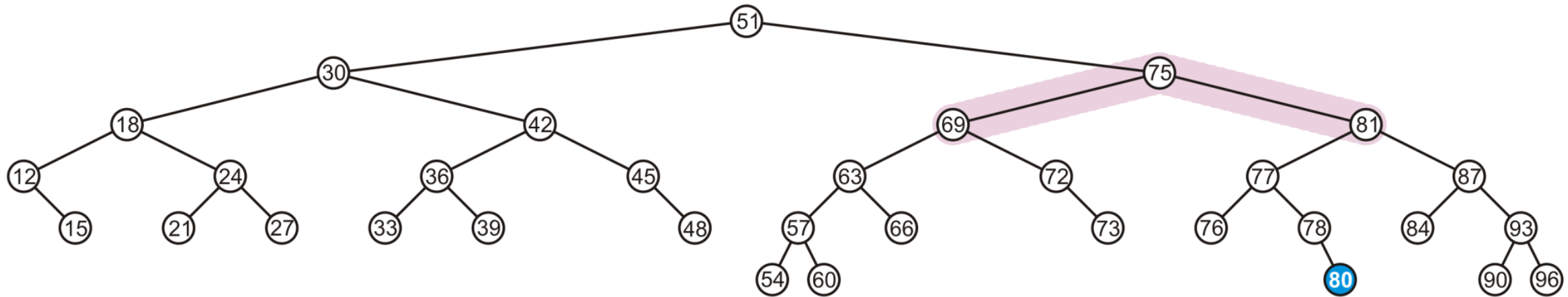

Insertion

Again, balanced

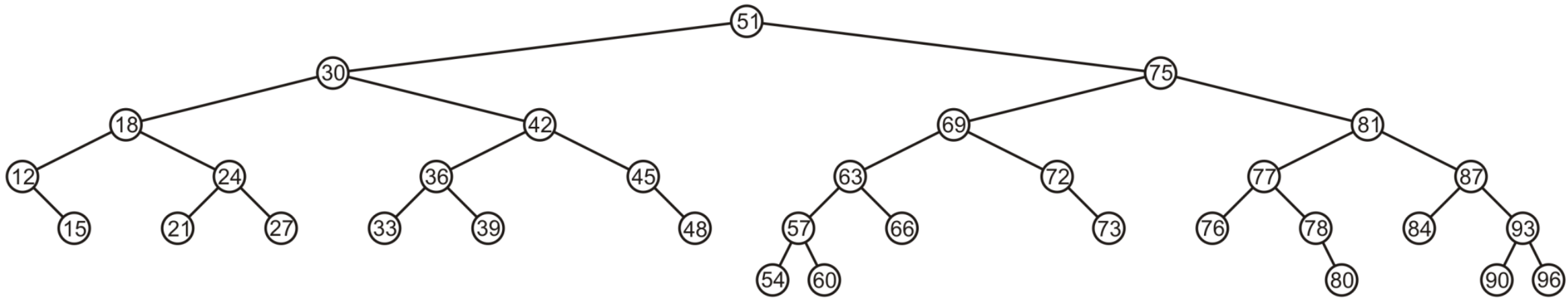

Insertion

Insert 74

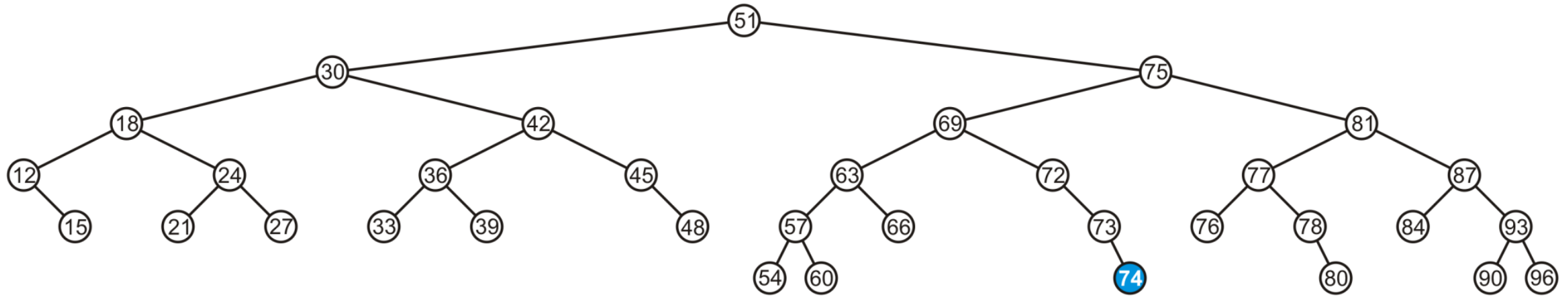

Insertion

The node 72 is unbalanced

- A right-right imbalance
- Promote the intermediate node to the imbalanced node

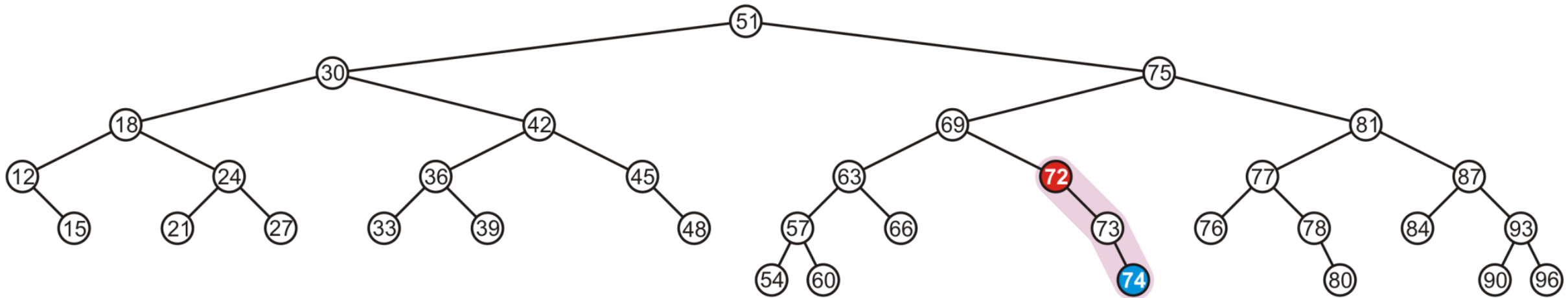

Insertion

The node 72 is unbalanced

- A right-right imbalance
- Promote the intermediate node to the imbalanced node

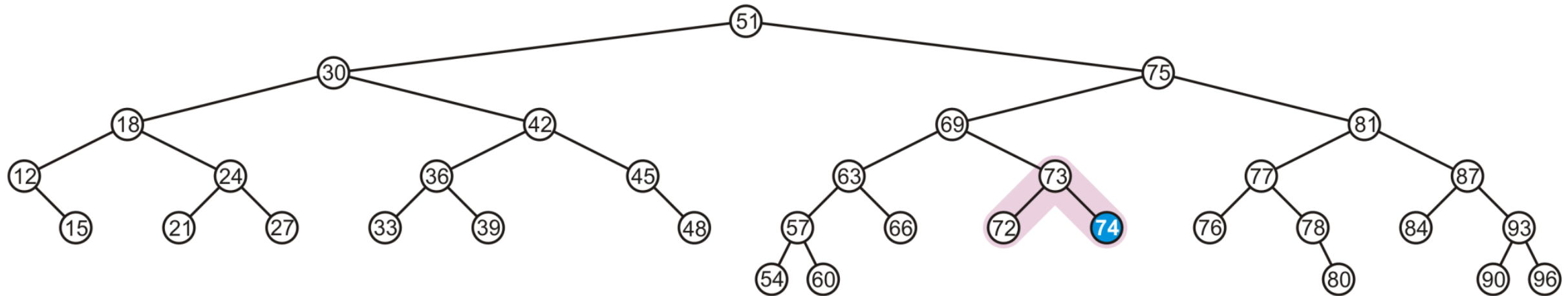

Insertion

Again, balanced

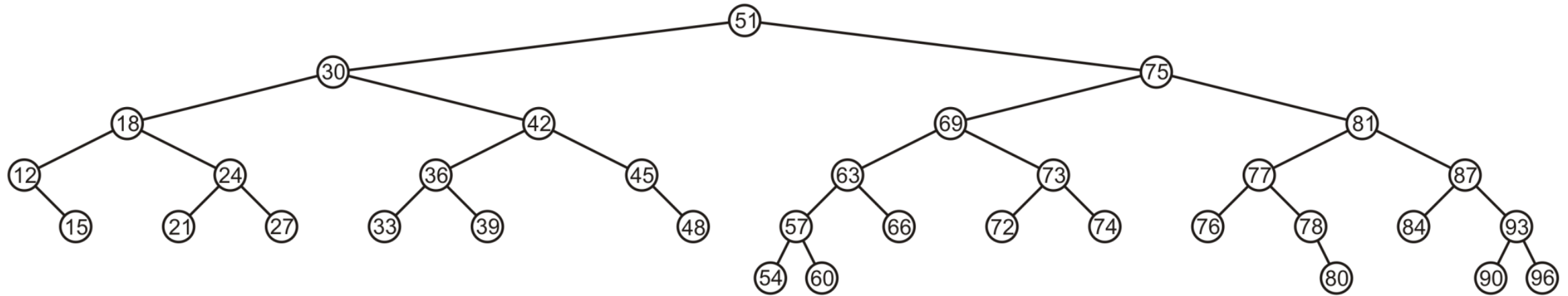

Insertion

Insert 55

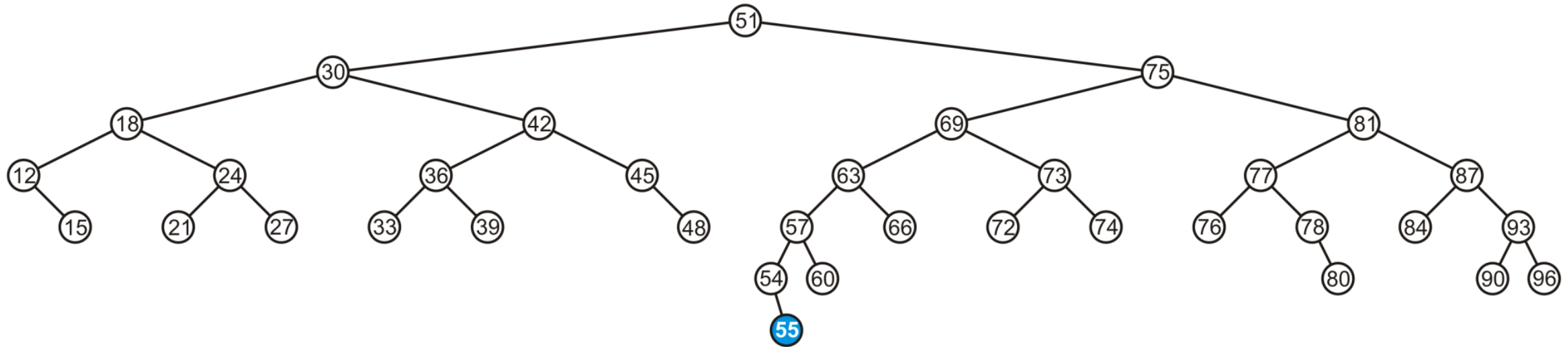

Insertion

The node 69 is imbalanced

- A left-left imbalance
- Promote the intermediate node to the imbalanced node

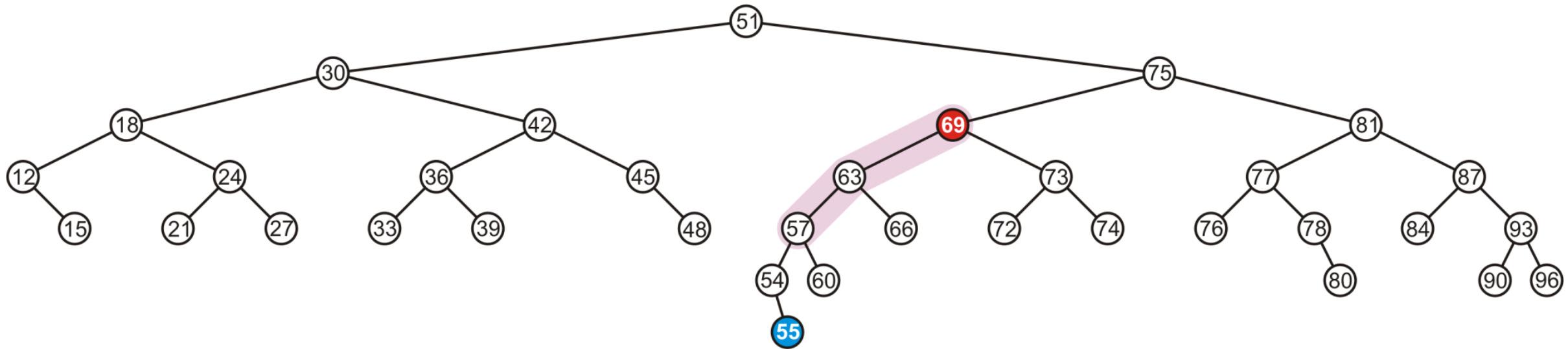

Insertion

The node 69 is imbalanced

- A left-left imbalance
- Promote the intermediate node to the imbalanced node
- 63 is that value

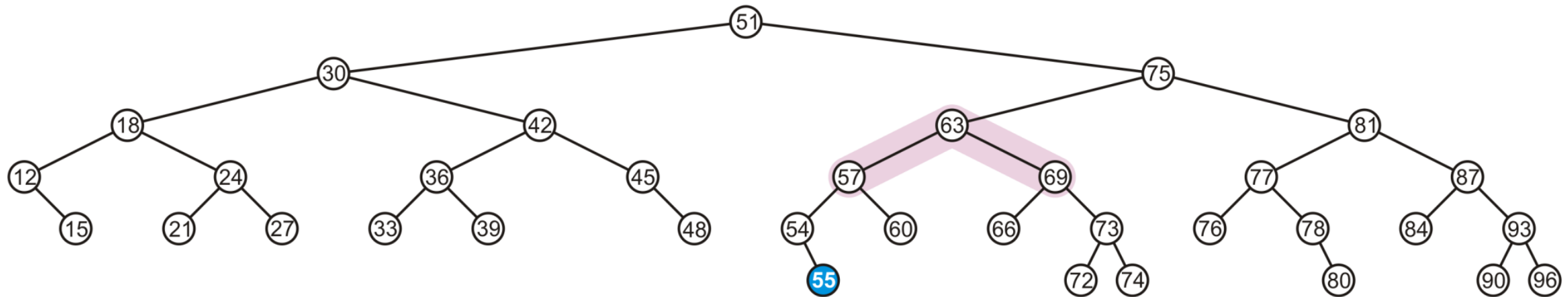

Insertion

Insert 55

- No imbalances

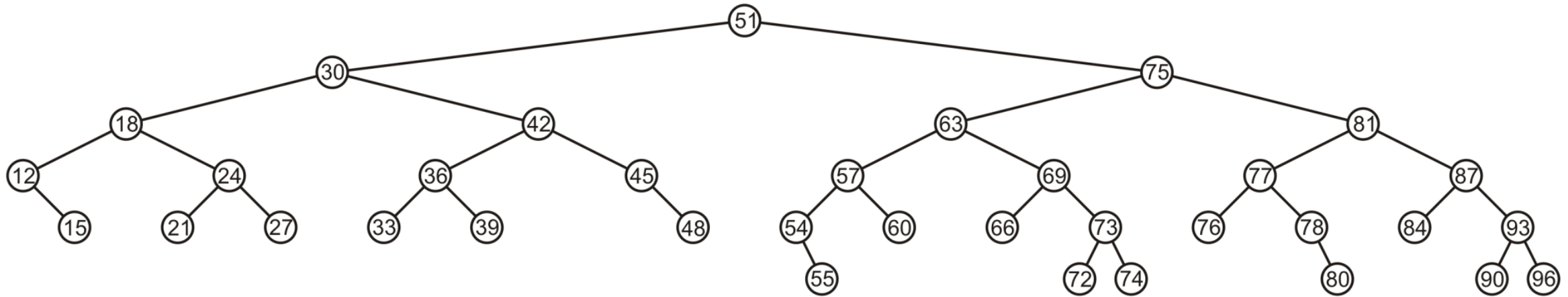

Insertion

Insert 67

Again, balanced

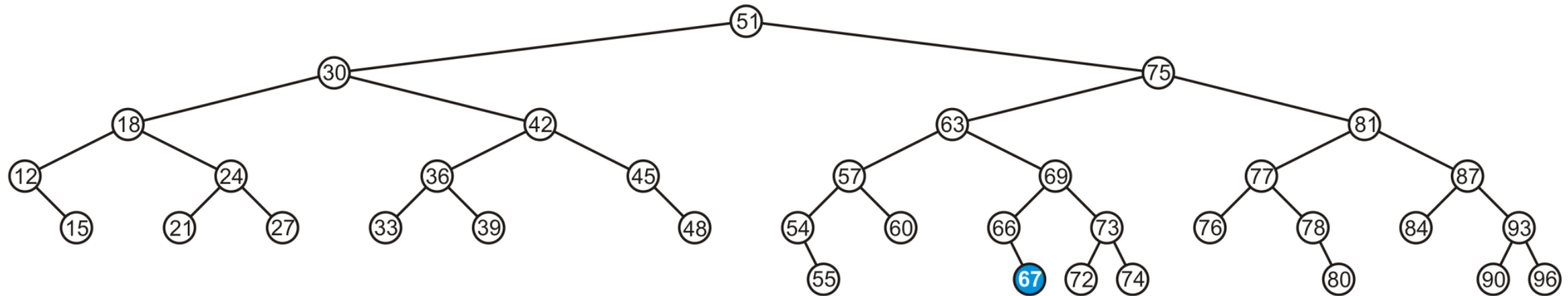

Insertion

Insert 70

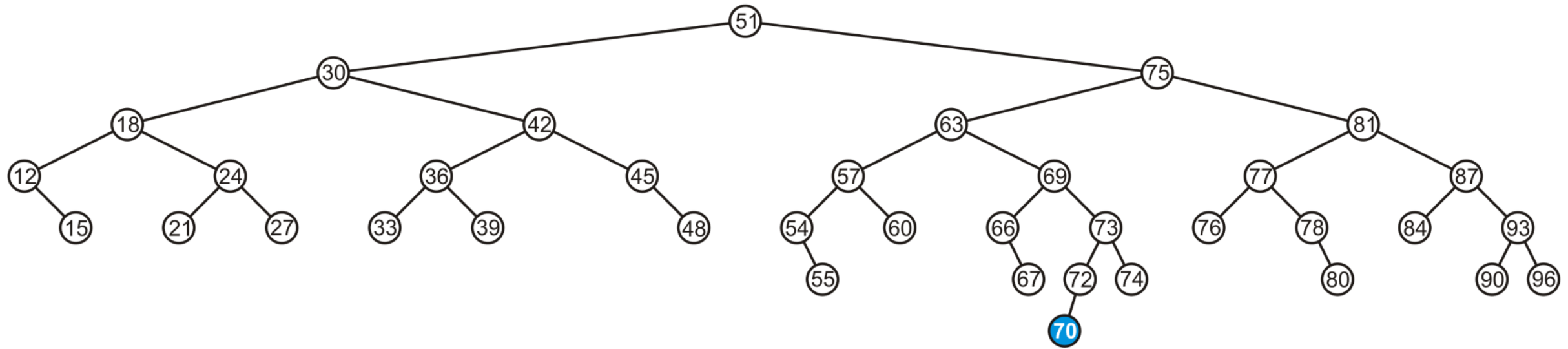

Insertion

The root node is now imbalanced

- A right-left imbalance
- Promote the intermediate node to the root

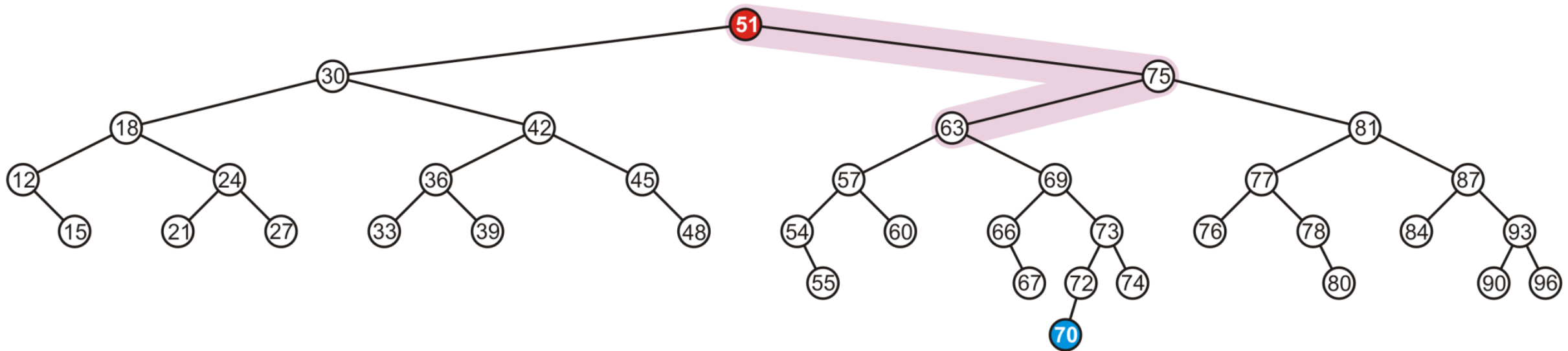

Insertion

The root node is imbalanced

- A right-left imbalance
- Promote the intermediate node to the root
- 63 is that node

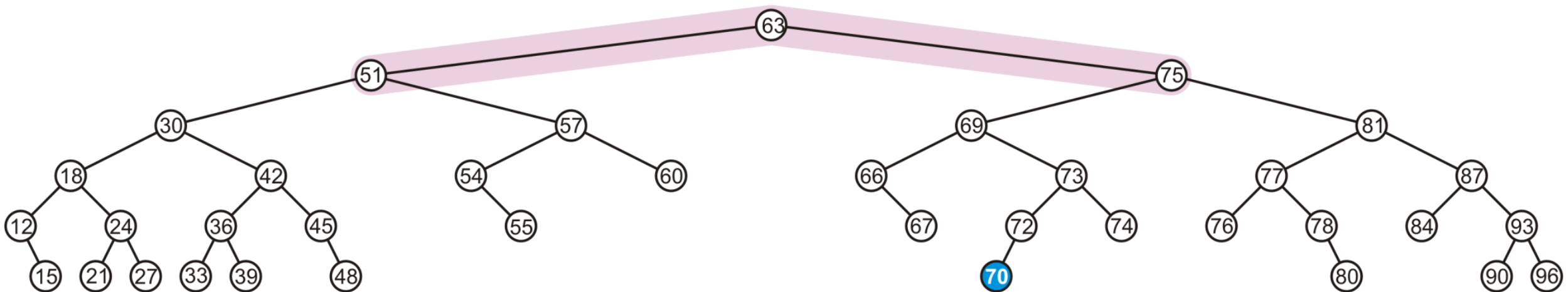

Insertion

The result is balanced

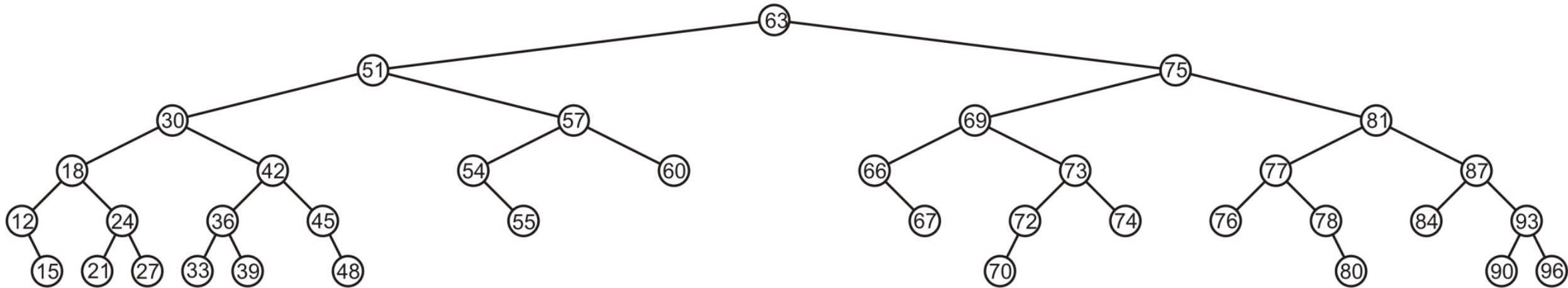

Insertion: Summary

Let the node that needs rebalancing be j .

There are 4 cases:

Outside Cases (require single rotation) :

1. Insertion into **left** subtree **of left** child of j .
2. Insertion into **right** subtree **of right** child of j .

Inside Cases (require double rotation) :

3. Insertion into **right** subtree **of left** child of j .
4. Insertion into **left** subtree **of right** child of j .

The rebalancing is performed through four separate rotation algorithms.

Outside and Inside Cases

Outside Case

Left subtree of left child

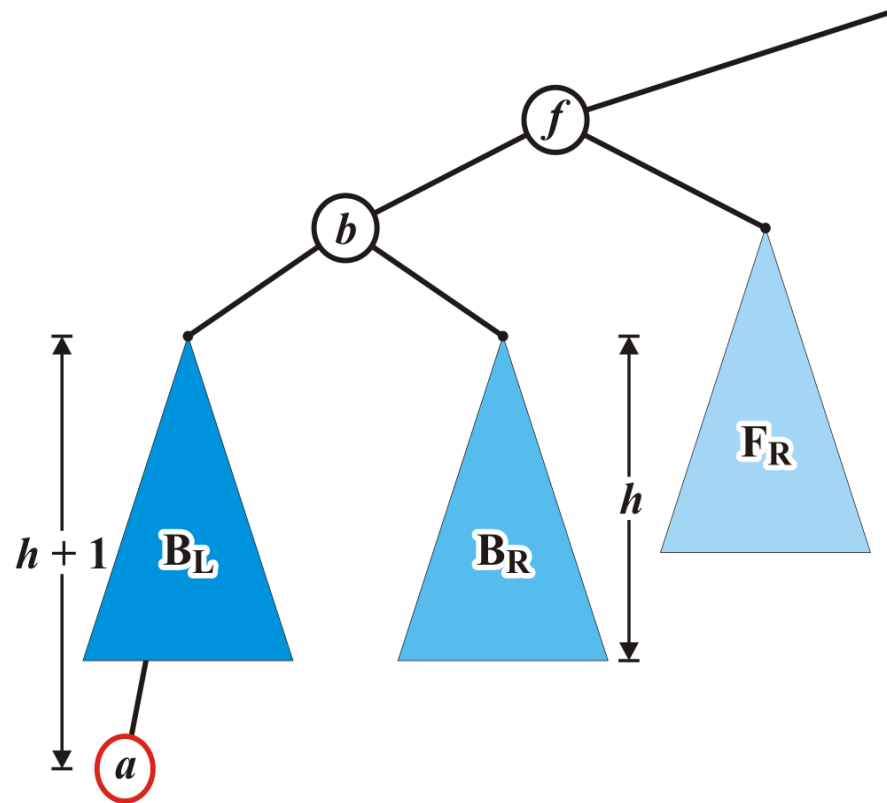

Single "right" Rotation

Inside Case

Right subtree of left child

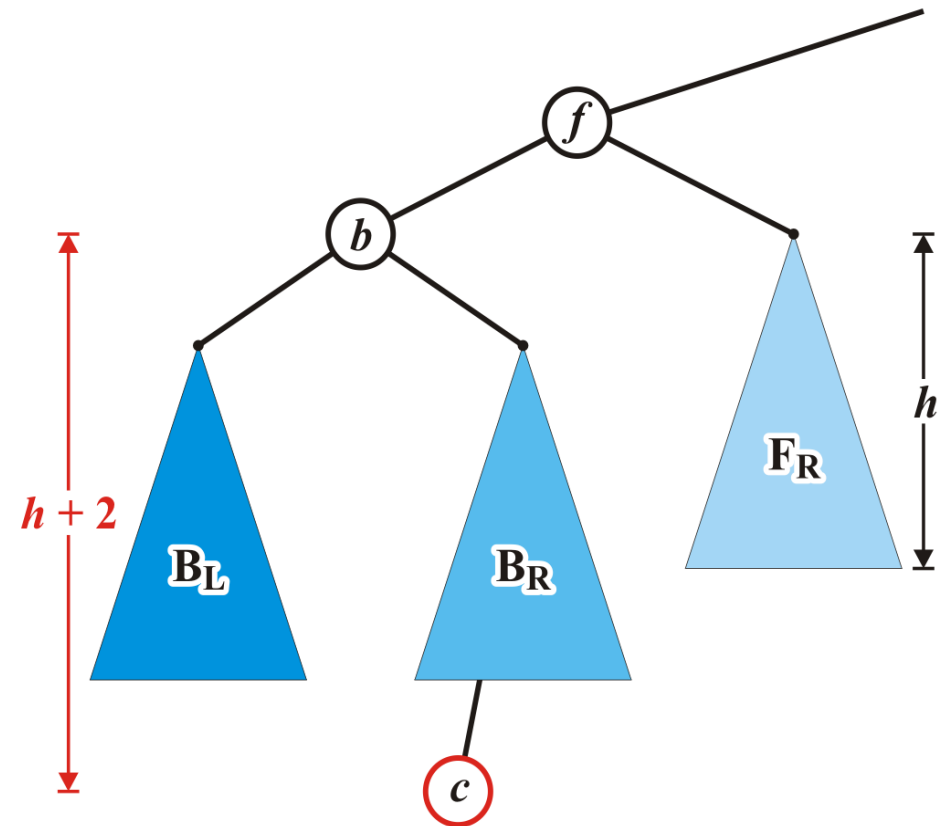

"left-right" Double Rotation

Inside Case Recap

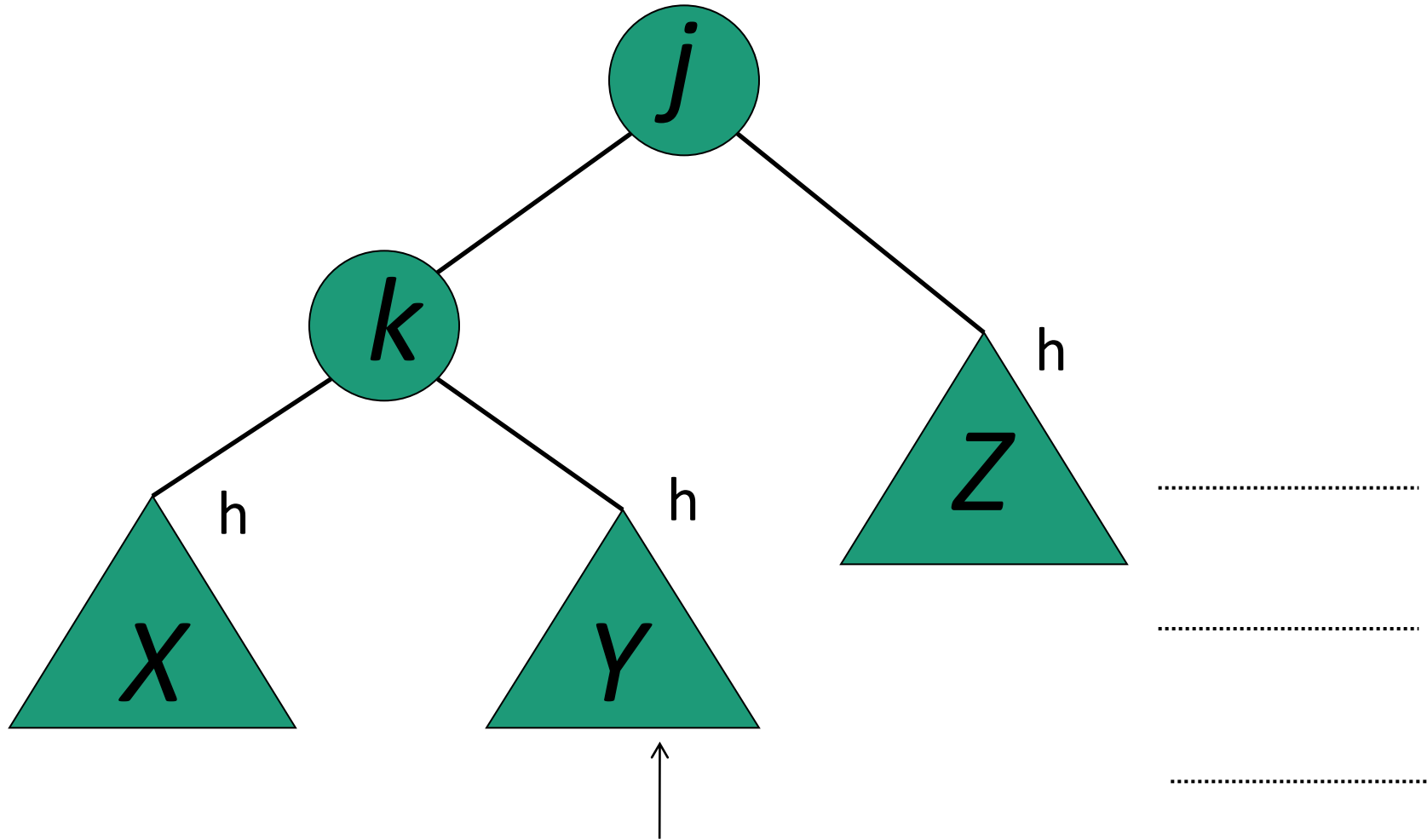

AVL Insertion: Inside Case

Consider the structure of subtree Y...

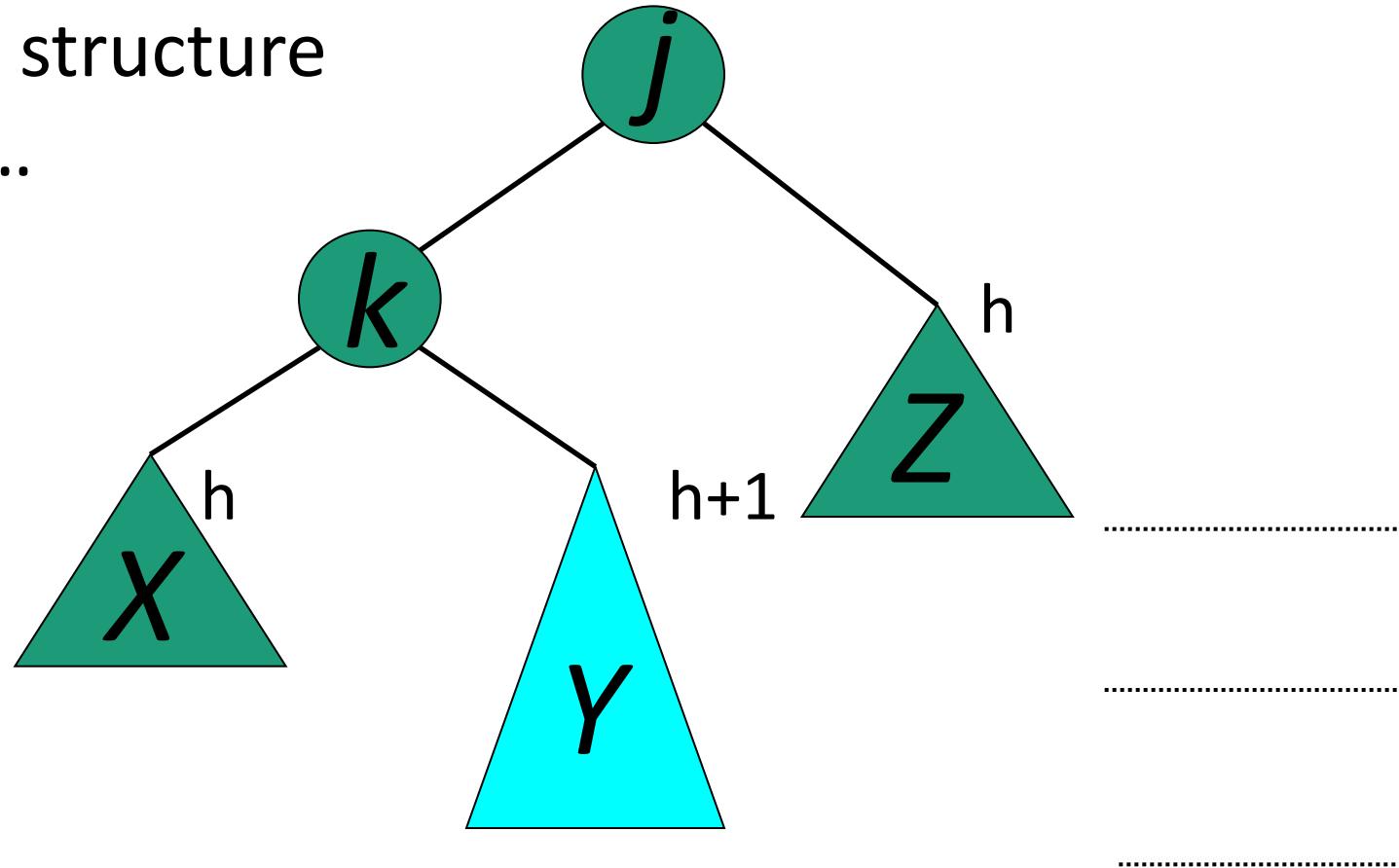

AVL Insertion: Inside Case

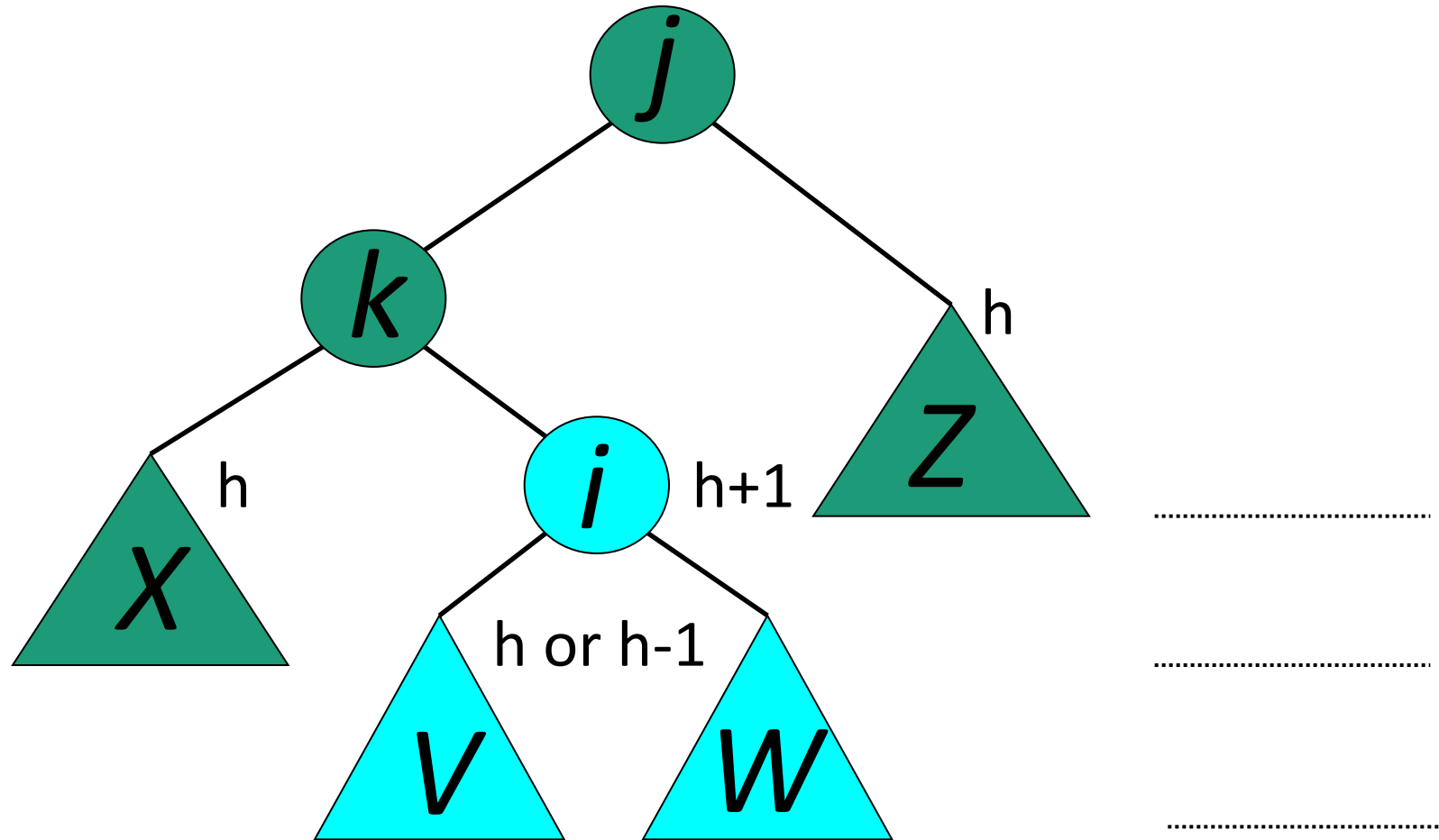

AVL Insertion: Inside Case

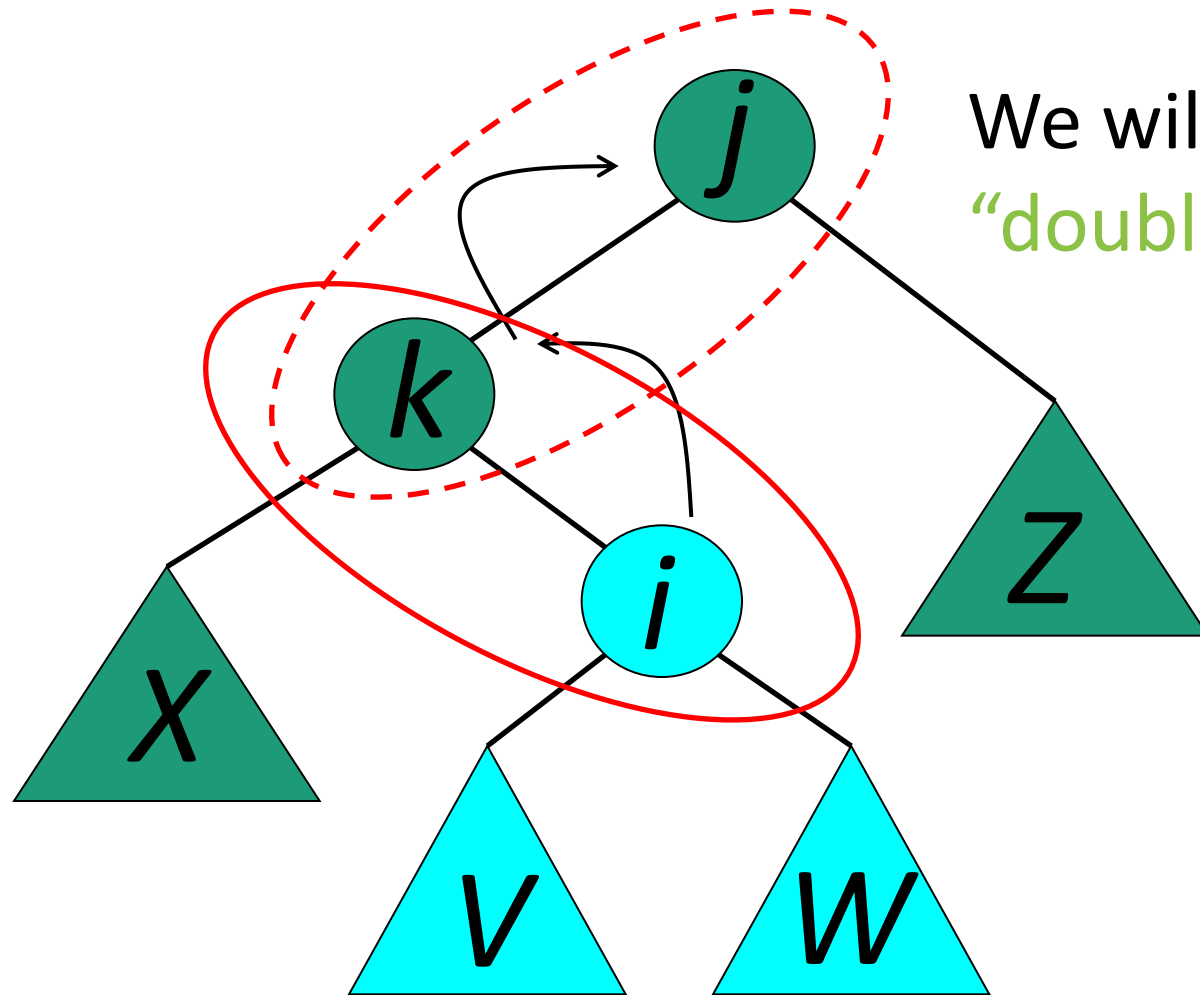

We will do a left-right
“double rotation” . . .

.....
.....
.....

Double rotation: first rotation

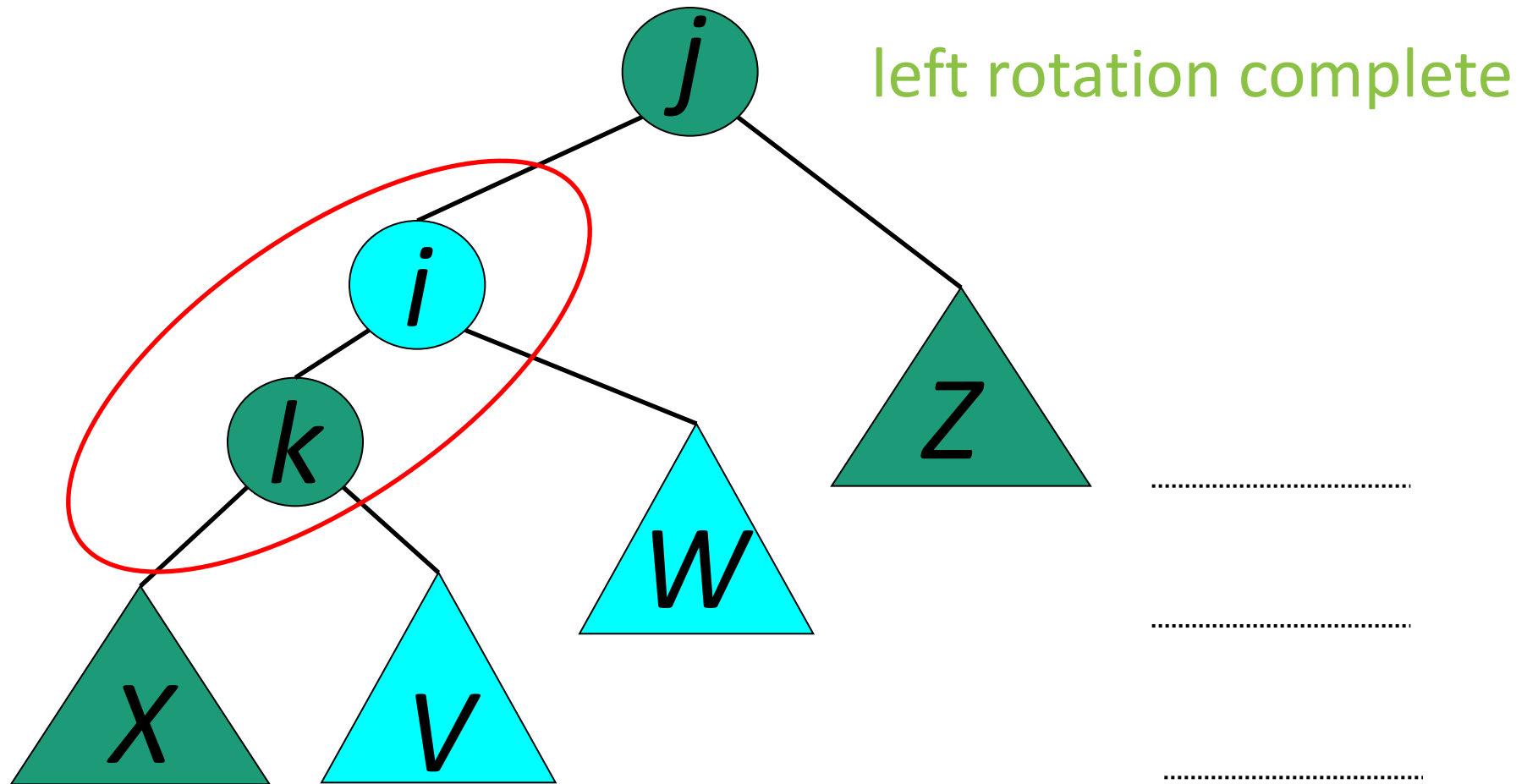

Double rotation: second rotation

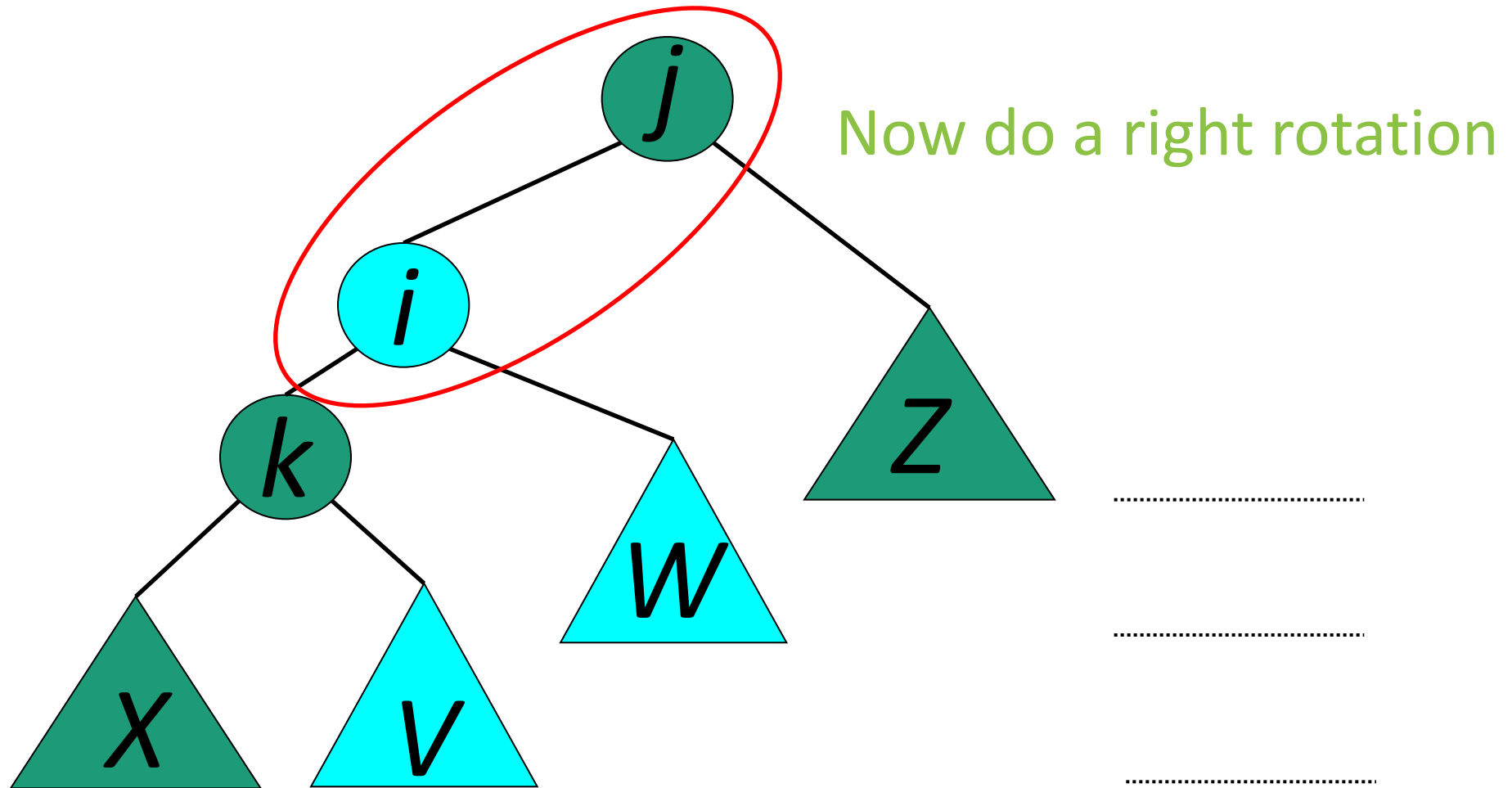

Double rotation: second rotation

right rotation complete

Balance has been restored

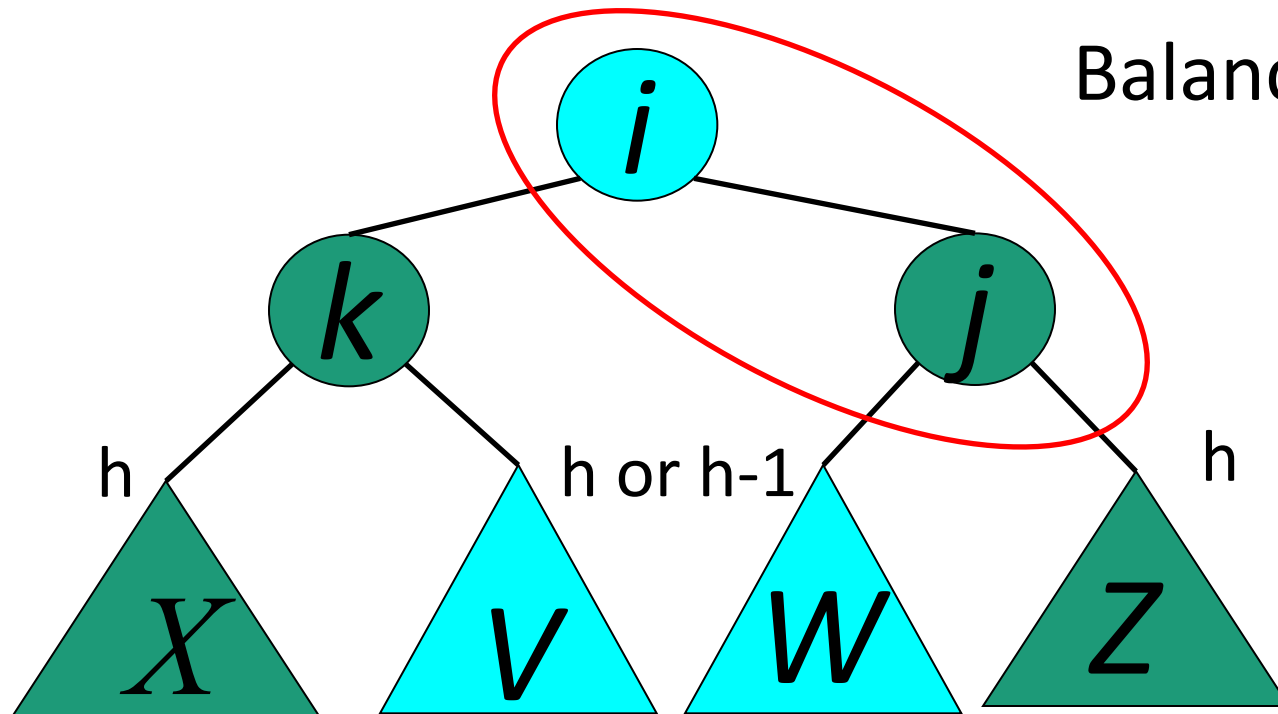

.....
.....
.....

Implementation

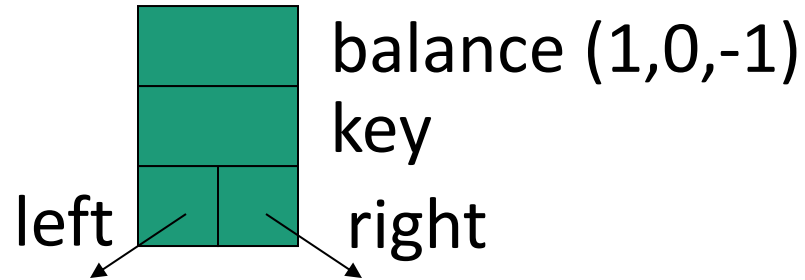

- No need to keep the height; just the difference in height, i.e. the **balance** factor; this has to be modified on the path of insertion even if you don't perform rotations
- Once you have performed a rotation (single or double) you won't need to go back up the tree

Insertion in AVL Trees

- Insert at the leaf (as for all BST)
 - only nodes on the path from insertion point to root node have possibly changed in height
 - So after the Insert, go back up to the root node by node, updating heights
 - If a new balance factor (the difference $h_{\text{left}} - h_{\text{right}}$) is 2 or -2 , adjust tree by *rotation* around the node

Correctness: Rotations preserve inorder traversal ordering

Deletion

Removing a node from an AVL tree may cause more than one AVL imbalance

- Like insert, erase must check after it has been successfully called on a child to see if it caused an imbalance
- Unfortunately, it may cause multiple imbalances that must be corrected
 - Insertions will only cause one imbalance that must be fixed

Deletion

Consider the following AVL tree

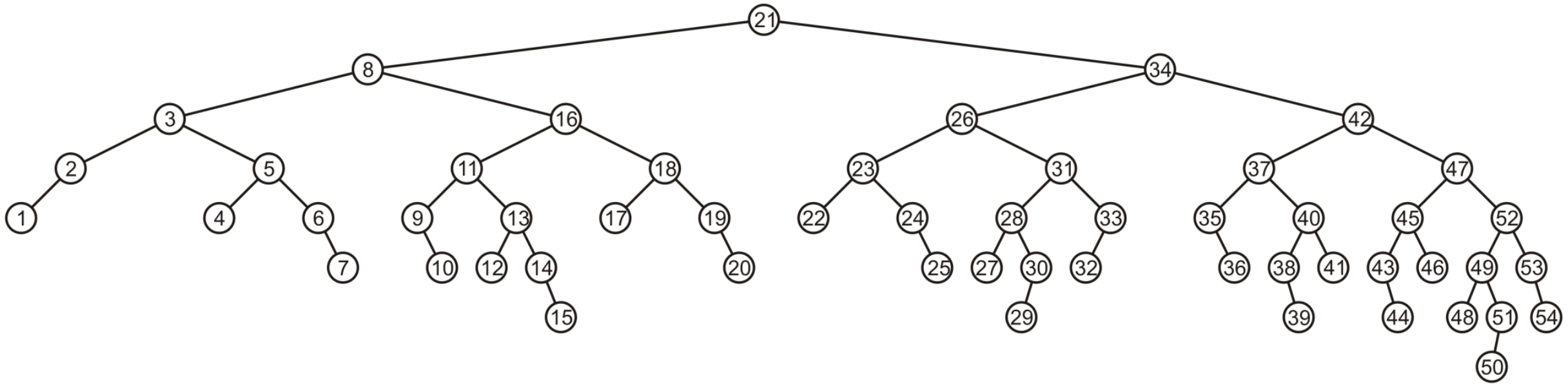

Deletion

Suppose we erase the front node: 1

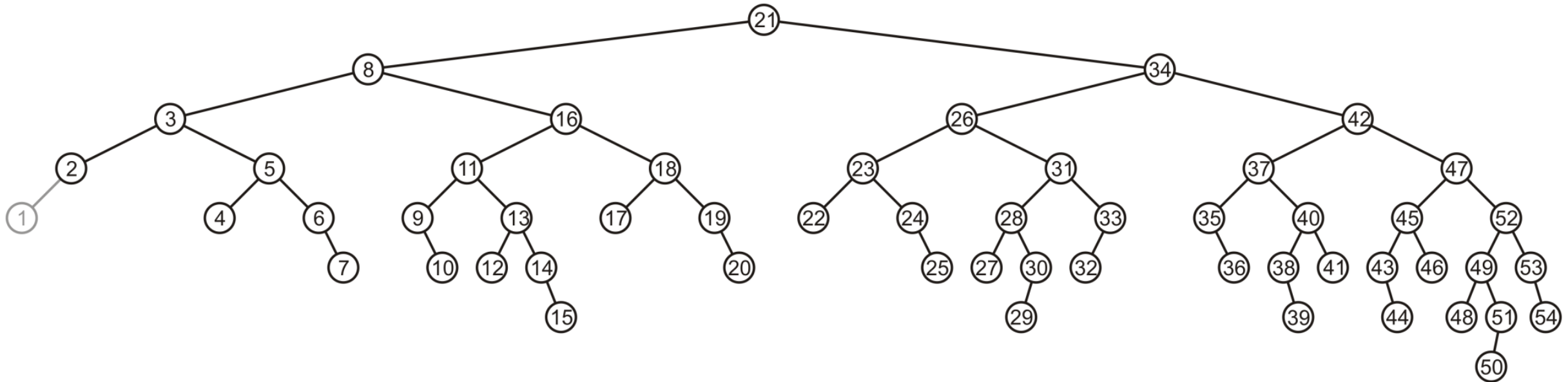

Deletion

While its previous parent, 2, is not unbalanced, its grandparent 3 is

- The imbalance is in the right-right subtree

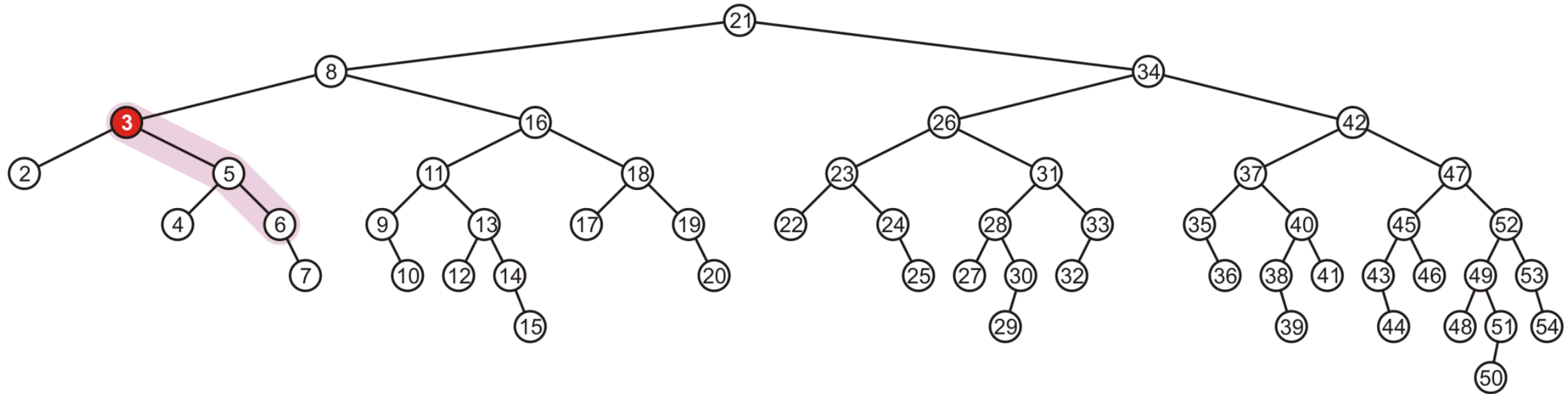

Deletion

We can correct this with a simple balance

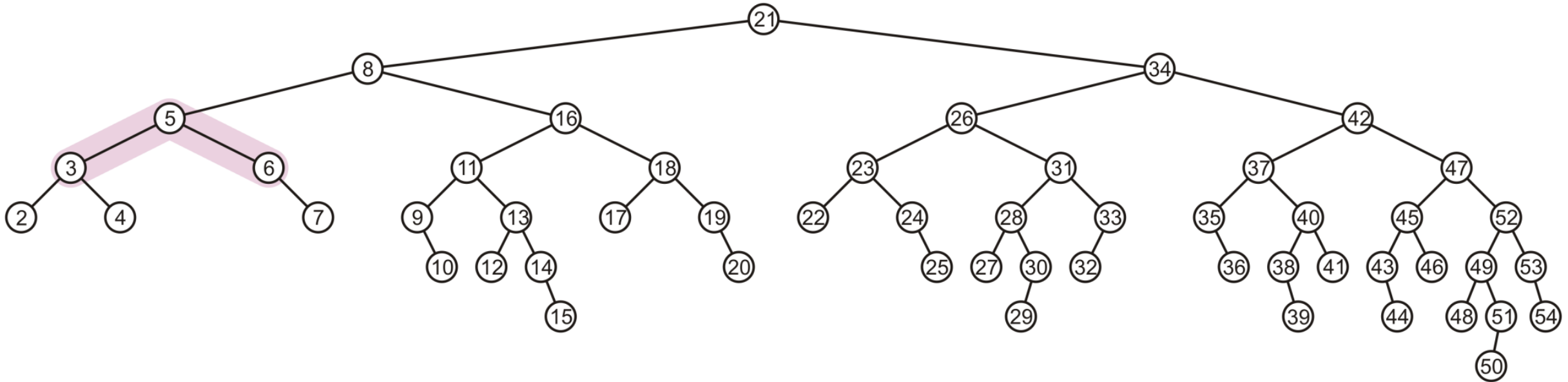

Deletion

The node of that subtree, 5, is now balanced

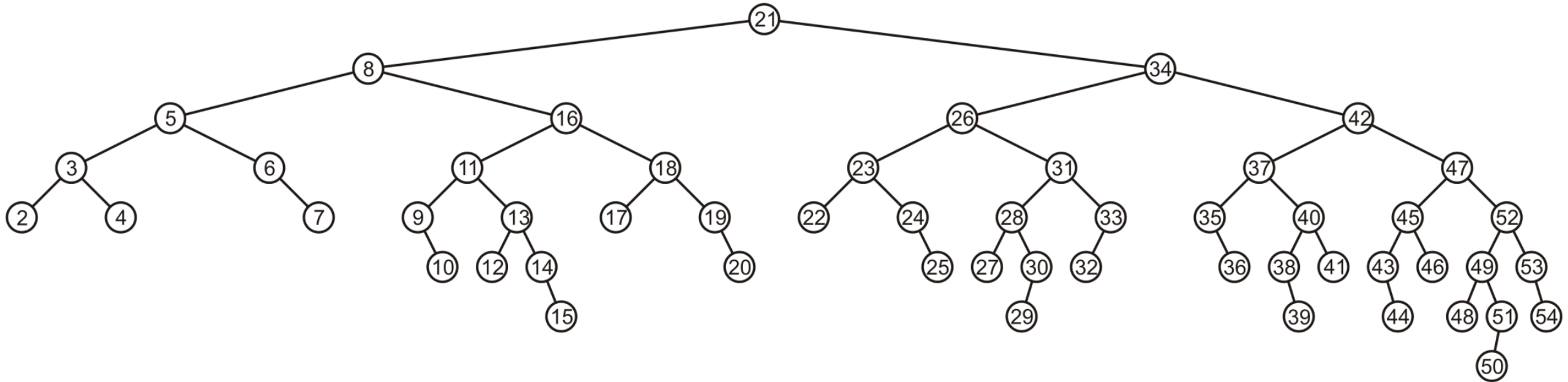

Deletion

Recurring to the root, however, 8 is also unbalanced

- This is a right-left imbalance

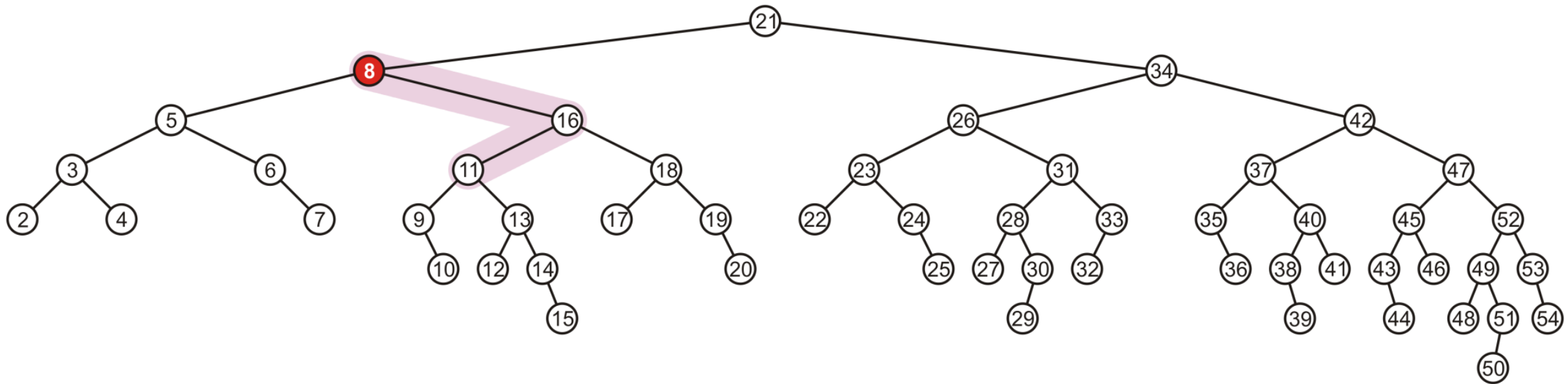

Deletion

Promoting 11 to the root corrects the imbalance

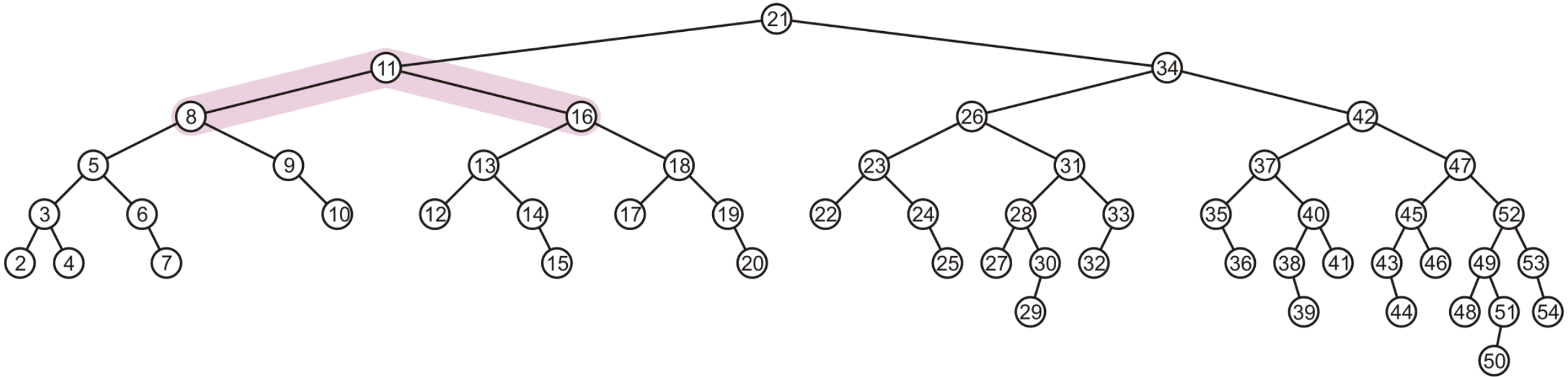

Deletion

At this point, the node 11 is balanced

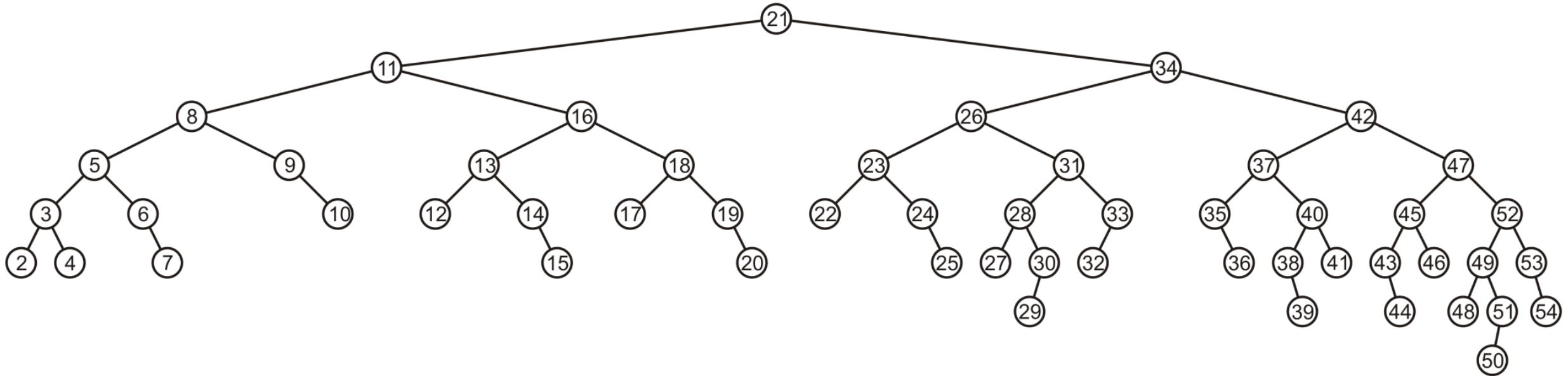

Deletion

Still, the root node is unbalanced

- This is a right-right imbalance

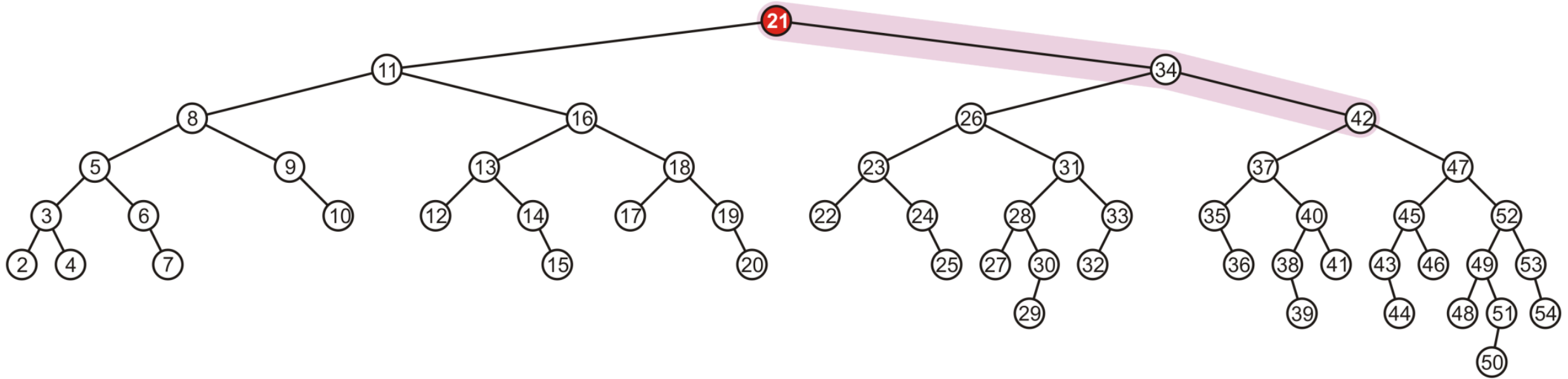

Deletion

Again, a simple balance fixes the imbalance

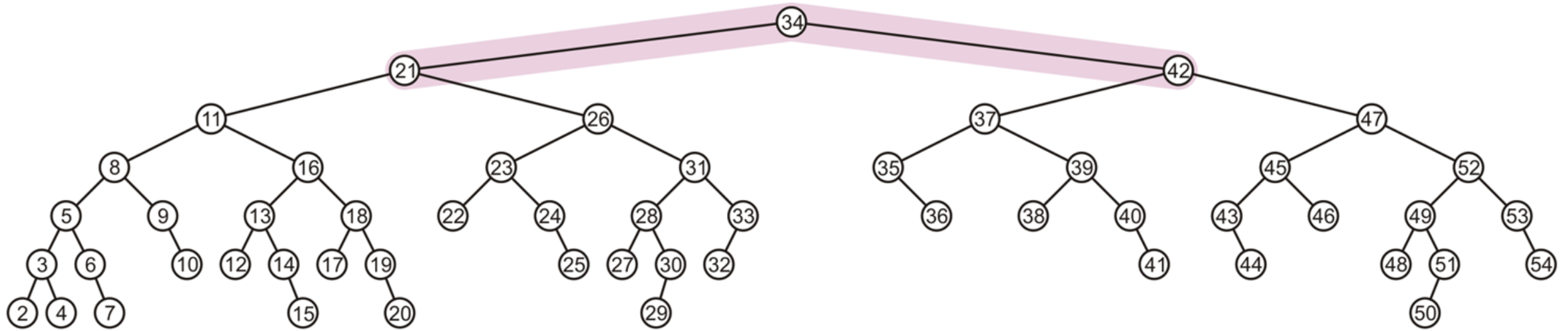

Deletion

The resulting tree is now AVL balanced

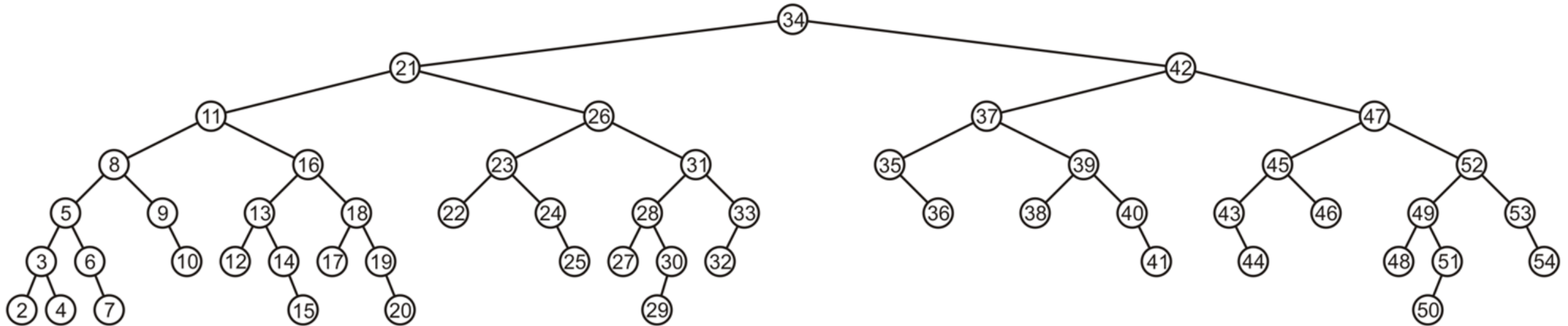

Pros and Cons of AVL Trees

Pros:

1. Search is $O(\log N)$ since AVL trees are **always balanced**.
2. Insertion and deletions are also $O(\log n)$
3. The height balancing adds no more than a constant factor to the speed of insertion.

Cons:

1. Difficult to program & debug; more space for balance factor.
2. Asymptotically faster but rebalancing costs time.
3. Most large searches are done in database systems on disk and use other structures (e.g. B-trees).
4. May be OK to have $O(N)$ for a single operation if total run time for many consecutive operations is fast (e.g. Splay trees).

Acknowledgement

- Stanford University
- University of Waterloo

Thank You